



power T&D

Specialized in self powered relays

SIA/SIL

Secondary and Primary Distribution Protection Relays

- Dual & Self Powered Relays
- Overcurrent & Earth Fault Protection Relays
- Feeder Protection Relays

IEC 61850

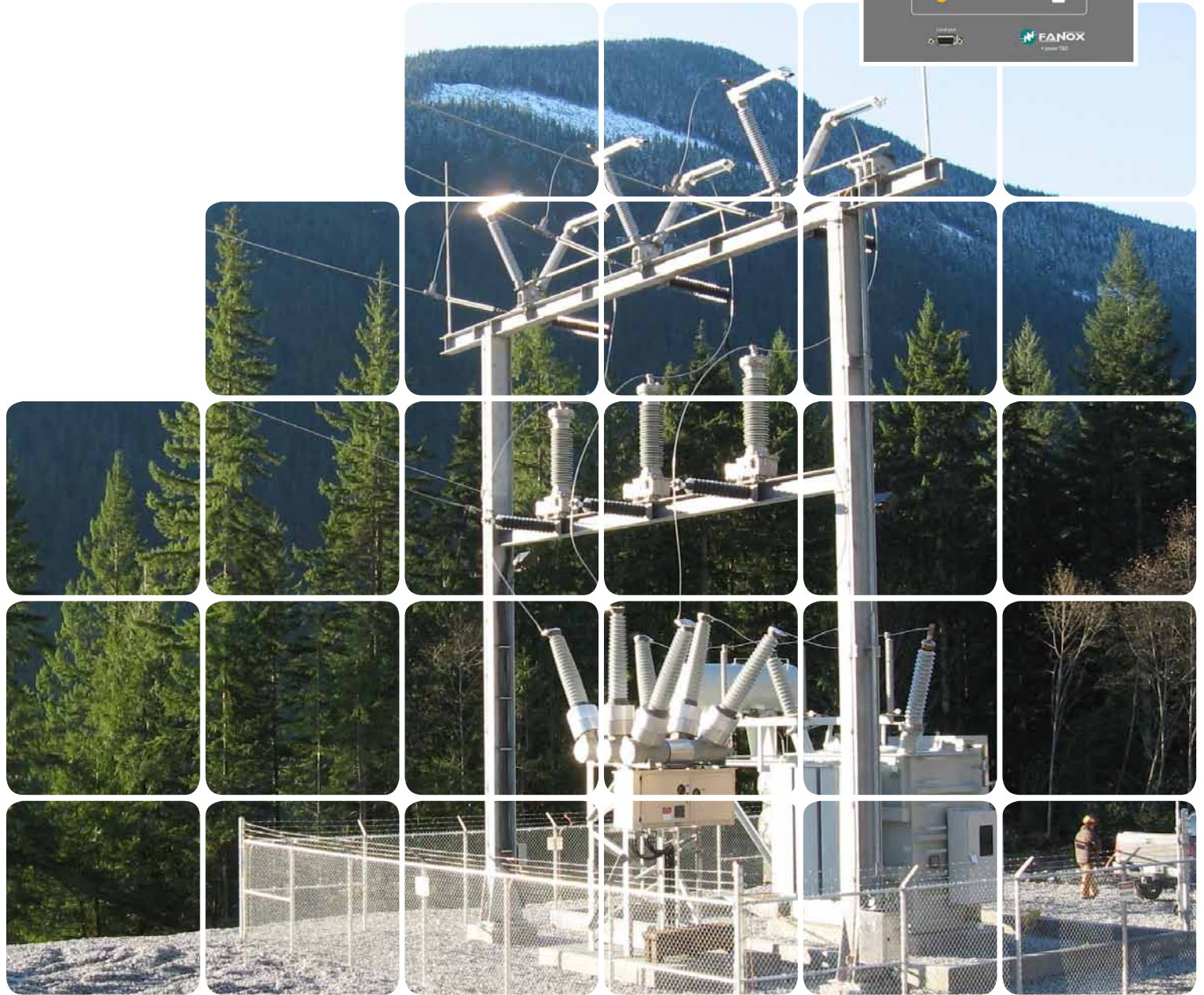
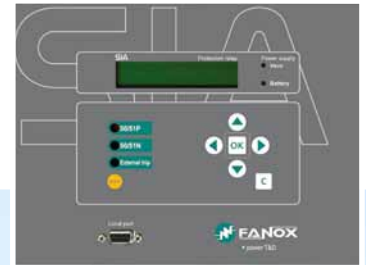

index

Introduction to SIA & SIL relays.....	4
Protection functions, common features and Standards	6
Selection guide.....	8
Application guide.....	10
Product specific information	
SIA-B Dual & Self powered	12
Main characteristics	12
Technical specifications	12
Model list.....	15
SIA-C Dual & Self powered	16
Main characteristics	16
Technical specifications	16
Model list.....	19
SIA-A/SIA-E Dual powered	20
Main characteristics	20
Technical specifications	21
Model list.....	23
SIA-F OC&EF for Secondary Distribution	24
Main characteristics	24
Technical specifications	24
Model list.....	27
SIA-D OC&EF for Secondary Distribution	28
Main characteristics	28
Technical specifications	28
Model list.....	31
SIL-A OC&EF for Primary Distribution	32
Main characteristics	32
Technical specifications	33
Model list.....	35
SIL-B Feeder Protection	36
Main characteristics	36
Technical specifications	37
Model list.....	41
Accessories.....	42



Through creativity, attention to customer needs, a wealth of experience, and extensive research, Fanox consistently delivers innovative products with unmatched features and performance.

Fanox, as an innovation driver and trendsetter, is establishing itself on the energy market as a powerful manufacturer of numerical protection relays that can be consistently used throughout all applications in the Transmission and Distribution networks.

With the SIA and SIL range operators have their systems firmly and safely under control, and have the basis to implement cost-efficient solutions for all duties in modern, intelligent and “smart” grids.



Introduction to SIA & SIL relays

Protection relays for Secondary Distribution. SIA

The range of SIA relays is designed to protect the secondary transformer and distribution substations of electrical networks. Features include protection against instantaneous and inverse time overcurrent (for phase and neutral) as well as an external trip support (temperature, pressure, etc.) for certain models.

The protection functions can be enabled by using both control panel and the communications link to the SCom programme. Combining the setting and IEC curves available, allows for precise coordination with other equipment.

Dual & Self powered protection relays

The outstanding feature of the SIA-C, SIA-B, SIA-E and SIA-A models is that they are dual/self-powered and function by employing the operating current of the installation. This means that maintenance of transformer and distribution substations is heavily reduced. All batteries, chargers and other external power elements are made redundant.

Furthermore a great advantage is that these relays ease commissioning and start-up of installations, and also make it easier to manage the equipment in adverse conditions. All models can be powered from an external battery portable kit (KITCOM), guaranteeing total operation of the relay, including trip functions occurring due to external faults



Self & Dual powered
Self & Dual powered

Protection relays for Primary and Secondary Distribution. SIL

The Energy sector is now in process of a deep transformation all over the world. Due to the high demand of energy, new distribution lines are needed as well as advanced systems of supervision. Assuming the need of intelligent infrastructures, FANOX has developed SIL family in order to perform this function.

Relays of SIL family, formed by SIL-A and SIL-B, are designed for protection of primary and secondary switching substations of electric distribution network. The protection features include protection against overcurrent (SIL-A and SIL-B), overvoltage (SIL-B) and undervoltage (SIL-B) but always with the option of reclosing in both models (SIL-A and SIL-B).

The protection functions can be enabled by using both the front panel and the communications link to the SCom programme.

The combination of the available IEC and ANSI curves and settings allows a precise combination with other equipments.

One advantage over other equipments available on the market is that SIL relays facilitate the start-up of installations and the carrying out specific operations in adverse conditions.

Communication protocols

Our relays incorporate new industry trends as remote communication to facilitate the implementation of Smart Grid and predictive maintenance network:

IEC 61850
IEC 60870-5-103
IEC 60870-5-104
DNP3.0
ModBus RTU



IEC 61850
IEC 61850

Protection functions & Standards

Function 50P

Instantaneous phase overcurrent

Function 50N and 50G

Instantaneous neutral overcurrent

Function 51P

Inverse time phase overcurrent

Function 51N and 51G

Inverse time neutral overcurrent

Curves IEC 60255-151 and ANSI

Standard curves are used for the protection functions

- 51P, 51N, 46, 67P y 67N:
- Normally inverse
- Very inverse
- Extremely inverse
- Definite time

Function 49

Thermal overload protection.

Function 49T (External Trip)

There is a direct trip input, normally associated with a bimetallic contact that is fitted to the power transformer, which serves as a backup for the current functions. In order for it to be a real backup, this input is not related to the protection processors. This means that the processors do not read the input and trip the striker, but the input acts directly on the striker, remaining operational for as long as the equipment is powered. This input is especially protected against electromagnetic noise.

Function 81U

Underfrequency protection

Function 81O

Overfrequency protection

Function 25

Synchronism check

Function 46

Inverse time negative sequence overcurrent

Function 59P

Defined time phase overvoltage

Function 59N

Defined time neutral overvoltage

Function 27P

Defined time phase undervoltage

Function 37

Phase undercurrent

Function 32/40

Defined time directional power

Function 79, auto-recloser

This function is the responsible of reclosing the breaker when a fault occurs.

Function 67P

It uses the voltage between phases as the polarization magnitude and the phase current as the operating variable. If the directional function 67P is not enabled, it behaves as a 51/50P function.

The operative time starts when the following conditions are met simultaneously:

- Polarization voltage higher than setting
- Phase current higher than setting
- Gap between phase current and polarization voltage is such that the phase current is within the area of the intervention.

Function 67N, Neutral directional protection

It uses the residual voltage as the polarization magnitude and the residual current as the operating variable. If the directional function 67N is not enabled, it behaves as a 50N Function. The operative time starts when the following conditions are met simultaneously:

- residual voltage higher than setting
- residual current higher than setting
- the gap between the residual current and residual voltage is such that the residual current is within the area of the intervention.

Trip Block for Switch disconnecter protection

Many transformation centers have a disconnecter as a break element. As line breakers have a limited opening current, with short-circuit events at high currents the responsibility for opening falls on the fuses, because otherwise, opening the line breaker would mean destroying it. In order to deal with these situations, tripping either in phase or neutral is blocked when the measured current exceeds a preset value.

Function 68, Logical Trip bus

Function 68 allows the creation of a coordinated net of equipments installed in different levels of the line which enables the blocking or the tripping and whose objective is clearing the fault in the least damaging place of the application.

Function 86

Function 86 allows to latch (lock out) the contact trip due to programmable logic (PLC).

Function 52

This function allows monitoring of circuit breaker state and makes a preventive maintenance.

Function 50BF

This function allows showing a possible error of the circuit breaker opening.

Function 74TCS, Trip Circuit Supervision

This function allows the supervision of breaker's trip circuit.

Function CLP, Cold Load Pick-up

This unit is used in order to avoid non-desirable operations of overcurrent functions when the line is not energized.



MEASUREMENTS

Phase and neutral are measured with an accuracy of $\pm 2\%$ over a band of $\pm 20\%$ of nominal and $\pm 4\%$ over the rest of the measurement range. The measurement range is for 0,02 until 30 times nominal current.

TIME SYNCHRONIZATION

- IRIG-B: GPS Time Synchronization Protocol
- Communications protocol synchronization.

SETTINGS GROUP

The relay has up to 3 settings group for the protections settings.

HMI

The HMI consists of:

- A 20x2 LCD screen with alphanumeric characters that allow the equipment parameters to be set (adjusted) and monitored (measurements, statuses, events).
- A membrane keyboard with six keys that allow you to navigate the menus and access information of interest. A seventh button "RESET", allows you to reset the bistable indicators and the events log. For security reasons, an access code is needed to modify the settings.
- LED indicators showing the type of power supply being used at all times. The relay can use more than one power source at one time.
- Bistable magnetic indicators that signal the cause of tripping. These indicators remain in position when the equipment loses power, reducing the time the maintenance service needs to identify the cause of tripping.

EVENTS RECORD

Events are recorded and ordered chronologically (up to 1000), allowing you to analyse what has happened with the installation over time (start-ups, tripping power supplies, etc.). They are recorded chronologically to the nearest millisecond in real time, thanks to the Real Time Clock (RTC). Events can be recorded on a non-volatile FRAM memory.

OSCILLOGRAPHY RECORDS

The relay stores up to 2 oscillographic logs and 20 fault reports, with a resolution of 16 samples/cycle. The oscillography can be downloaded by communications through the Modbus protocol. The SiCom communications program allows the oscillography to be downloaded and saved in COMTRADE format (IEEE C37.111-1991).

COM. PORTS

The relay has up to 3 communication ports in different format: USB, RS232, RS485, FOP, FOC, RJ45 (Ethernet).

COM PROTOCOLS

The relay supports the different protocols: ModBus RTU, IEC60870-5-103, IEC60870-5-104, DNP3.0 (TCP/IP), IEC61850.

COMMUNICATIONS

The relays have a communication local port on the front of the equipment and rear ports on the back for remote communication.

The SiCom software with Windows® 2000/XP and Windows® 7 uses a graphic user interface to allow you to access all equipment information, modify the settings and save events. The software can be used locally by using the front port or remotely by using the rear RS485 port when the protocol is ModBus RTU.

TEST MENU

This allows you to use the HMI to verify correct operation of the LEDs, the bistable magnetic indicators, the trip contact and the output. Activating the trip contact from the test menu allows you to verify correct operation of the opening mechanism simply.

SELF-DIAGNOSIS

Diagnostic algorithms to generate the corresponding events are executed on starting up the equipment and all the time the relay is operating.

STANDARDS

- IEC 61000-4-2 Immunity Tests to Electrostatic Discharges
- IEC 61000-4-3 Immunity Tests to Radiated Radiofrequency Electro-magnetic Fields
- IEC61000-4-4 Immunity to Electrical Fast Transients (EFT)
- IEC 61000-4-5 Immunity to surges
- IEC 61000-4-6 Immunity to Conducted RF
- IEC 61000-4-8 Power frequency magnetic field immunity test
- IEC 61000-4-9 Immunity to Pulsed Magnetic Fields
- IEC 61000-4-10 Immunity to Damped Oscillating Magnetic Fields
- IEC 61000-4-11 Immunity to gaps and variations of AC voltage
- IEC 61000-4-12 Immunity to damped RF oscillatory waves
- IEC 61000-4-14 Voltage fluctuation immunity test
- IEC 61000-4-17 Residual waves in the power DC input
- IEC 61000-4-18 Damped oscillatory wave immunity test
- IEC 61000-4-27 Imbalance
- IEC 61000-4-29 Voltage dips, short interruptions and voltage variations (direct current)
- IEC 60255-5 Dielectric Test
- IEC 60255-5 Isolation resistance test
- IEC 60255-5 Impulse voltage test
- EN 60068-2-1 Cold
- EN 60068-2-2 Dry heat
- EN 60068-2-14 Change of temperature
- IEC 60255-21-1 Vibrations tests (sinusoidal)
- IEC 60255-21-2 Shock and bump tests
- IEC 60255-21-3 Seismic tests
- EN 50263 Generic measurement standard for relays and protection equipments
- EN 61000-6-4 Generic standard for emissions in an industrial environment
- EN 61000-6-2 Generic standard for immunity in an industrial environment
- EN 55011 and EN 55022 RF Emissions
- IEC 60255-22-1 Immunity to damped RF oscillatory waves
- Fanox Quality Management

Product selection guide

	SELF & DUAL POWERED			
	SIA-B	SIA-C	SIA-A	SIA-E
Auxiliary Supply	24Vdc 110Vac 230Vac	24Vdc 110Vac 230Vac	230Vac	230Vac
Self Power Supply	3.2A* x3	0.1 In	4A x3	2A x3
External battery	KITCOM	KITCOM	KITCOM	KITCOM
Consumption	0,5 W	0,5 W	0,5 W	0,5 W
CT	Dual Core	Standard 2,5VA	Dual Core	Dual Core
LPCT				
50P	1	2	1	1
50G		2	1	1
50N	1			
50/51P	1	1	1	1
50/51G		1	1	1
50/51N	1			
52				
50BF				
49				
49T	1	1	1	1
79				
46				
CLP				
74TCS				
Trip Block	1		1	1
68 (Trip Bus)		1		
86				
Programmable Logic (PLC)				
50/51/67N				
50/51/67P				
37				
59P				
59N				
27P				
32/40				
81U/O				
25				
IRIG-B				
Counters				
Commands				
Sett. Group	2	3	1	1
Inputs	1	2	1	1
Outputs	1	2 + 1	1	1
STRIKER	24 Vdc – 288 mJ	24 Vdc – 288 mJ	6 Vdc – 4 mJ	6 Vdc – 4 mJ
LEDs	2+1MAG.FLAG	3+3 MAG.FLAG	3+3 MAG.FLAG	3+3 MAG.FLAG
HMI	20X2 LCD + 7 key	20X2 LCD + 7 key	20X2 LCD + 7 key	20X2 LCD + 7 key
52 & 79 HMI				
Event	100	500	100	100
Fault Report				
Oscillography				
Local Port (frontal)	USB	RS232	RS232	RS232
Remote Port (rear)		RS485		
Communications Protocols	ModBus RTU	ModBus RTU	ModBus RTU	ModBus RTU
Size of	4U x 1/4 rack	4U x 1/3 rack 4U x 3/5 rack	5U x 1/3 rack	4U x 1/2 rack

*Depending on the CT used: 3.2A, 6.4A, 12.8A, 25.6A or 51.2A (x3)

OC & EF for Secondary Distribution		OC & EF for Primary Distribution	FEEDER PROTECTION
SIA-F	SIA-D	SIL-A	SIL-B
24-48Vdc 90-300Vdc/110-230Vac	24-48Vdc 90-300Vdc/110-230Vac	24-48Vdc 90-300Vdc/110-230Vac	24-48Vdc 90-300Vdc/110-230Vac
KITCOM	KITCOM		
1,5 – 2,2 W	1,5 – 3 W	3,3 – 4,5 W	3,3 – 5,5 W
Standard 0,5VA	Standard 0,5VA	Standard 0,5VA	Standard 0,5VA
		✓	
1	1	2	2
1	1	2	2
1	1	1	
1	1	1	
1	1	1	1
1		1	1
1		1	1
1		1	1
		1	1
		1	1
		1	1
1	1		
	1		
✓			
V2	V1	V1	V1
	2		2
			2
			2
			2
			2
			2
			2
			4
			4
			1
			✓
✓	✓	✓	✓
✓	✓	✓	✓
2	1	3	3
2	4	4+4	4+4
2 + 1	2 + 1 + 1	3 + 2	5 + 2
3 configurable	3+3 MAG.FLAG	6 configurable	6 configurable
20X2 LCD + 7 key	20X2 LCD + 7 key	20X2 LCD + 7 key	20X2 LCD + 7 key
		2 led's + 3 key	2 led's + 3 key
100	500	1000	1000
4	2	20	20
	2 record x 33 cycles	2 record x 220 cycles	2 record x 138 cycles
USB	RS232/USB	RS232	USB
RS485	RS485	RS485 + RS485 Ethernet + RS485	RS485 + RS485 Ethernet + RS485
ModBus RTU	ModBus RTU	ModBus RTU IEC60870-5-103 IEC60870-5-104 DNP3.0 (TCP/IP) IEC61850	ModBus RTU IEC60870-5-103 IEC60870-5-104 DNP3.0 (TCP/IP) IEC61850
4U x 1/4 rack	4U x 1/2 rack	4U x 1/2 rack	4U x 1/2 rack

PRODUCT APPLICATION GUIDE

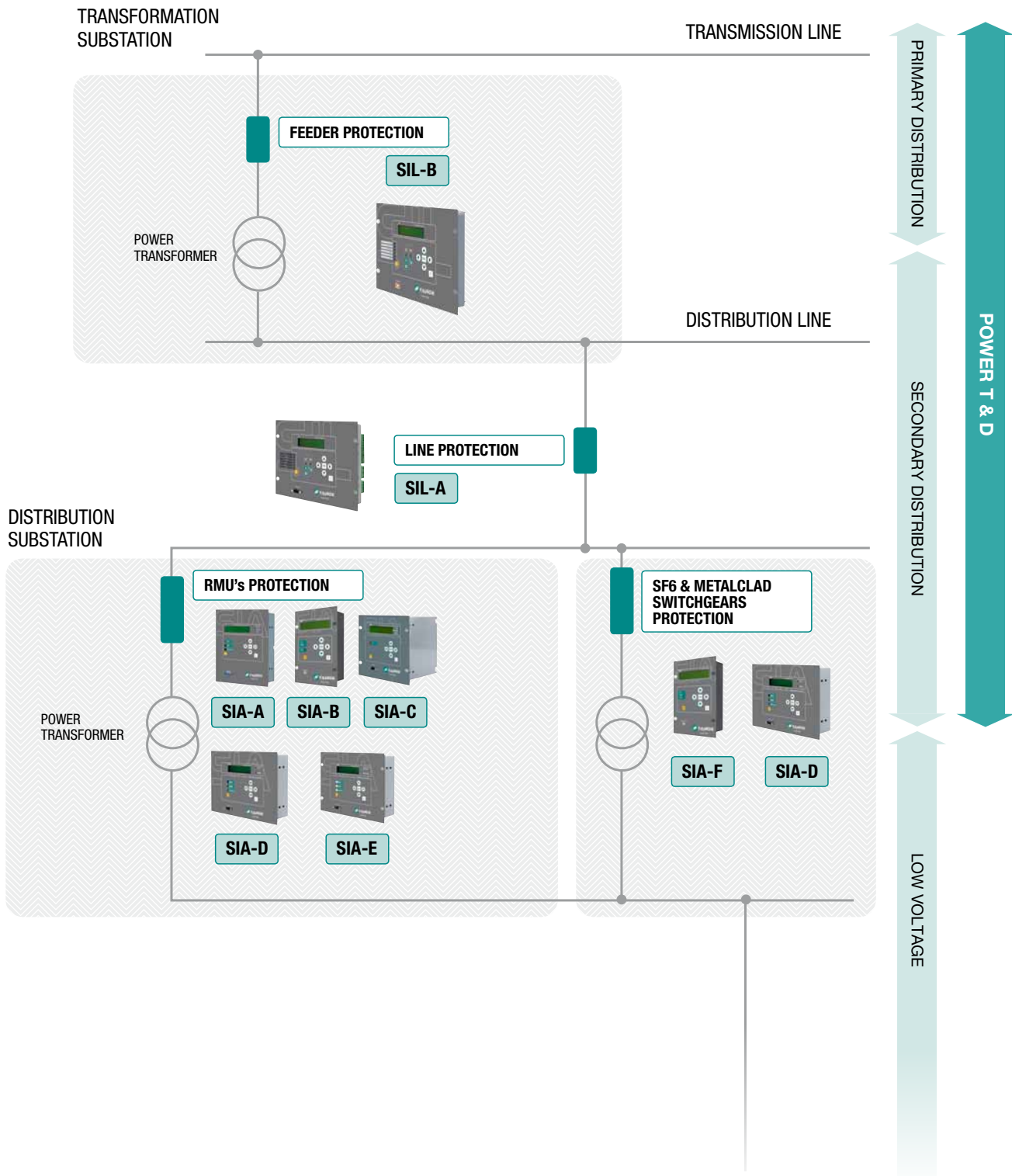

SIA-B

SIA-C

SIA-A

SIA-E

SIA-F

SIA-D

SIL-A

SIL-B

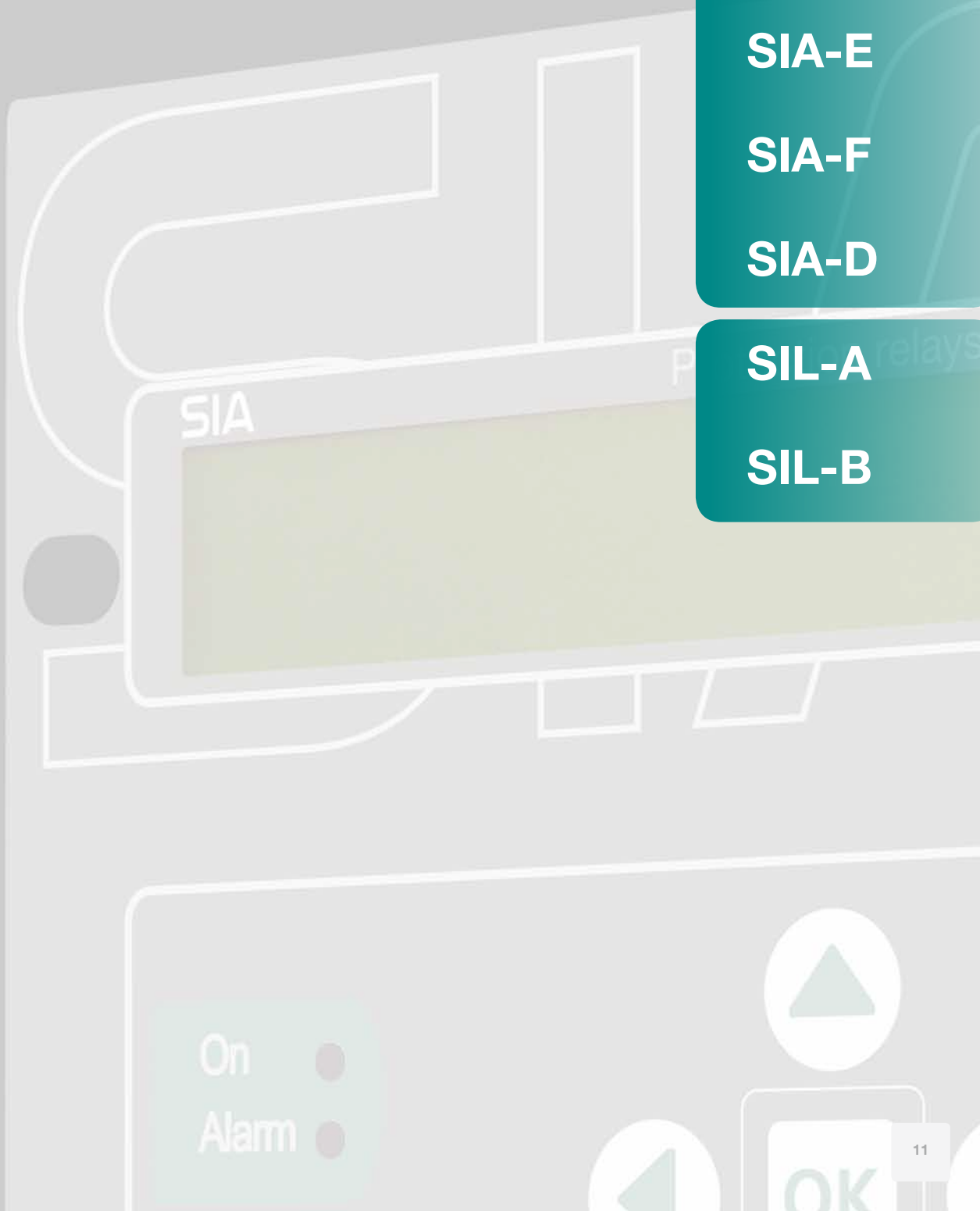

SIA-B

DUAL & SELF POWERED OVERCURRENT AND EARTH FAULT PROTECTION RELAY FOR SECONDARY DISTRIBUTION



Main characteristics

- 50P, 51P, 50N, 51N, 50G, 51G, 49T protection functions
- Trip block for switch disconnector
- Compact size
- Low power consumption (0,5 W, 24 Vdc)
- Non-volatile RAM memory in order to store up to 100 events
- USB connection on the front (Modbus RTU communication protocol)
- FLAG indicator for the trip
- Both in dual & selfpowered modes, SIA-B starts-up from 0.4 Is of primary three phase current using specific CTs.

Is	CT nominal range
8	8 - 32 (A)
16	16 - 56 (A)
32	32 - 112 (A)
64	64 - 224 (A)
128	128 - 448 (A)
256	256 - 896 (A)

Technical specifications SIA-B

Functions diagram SIA-B

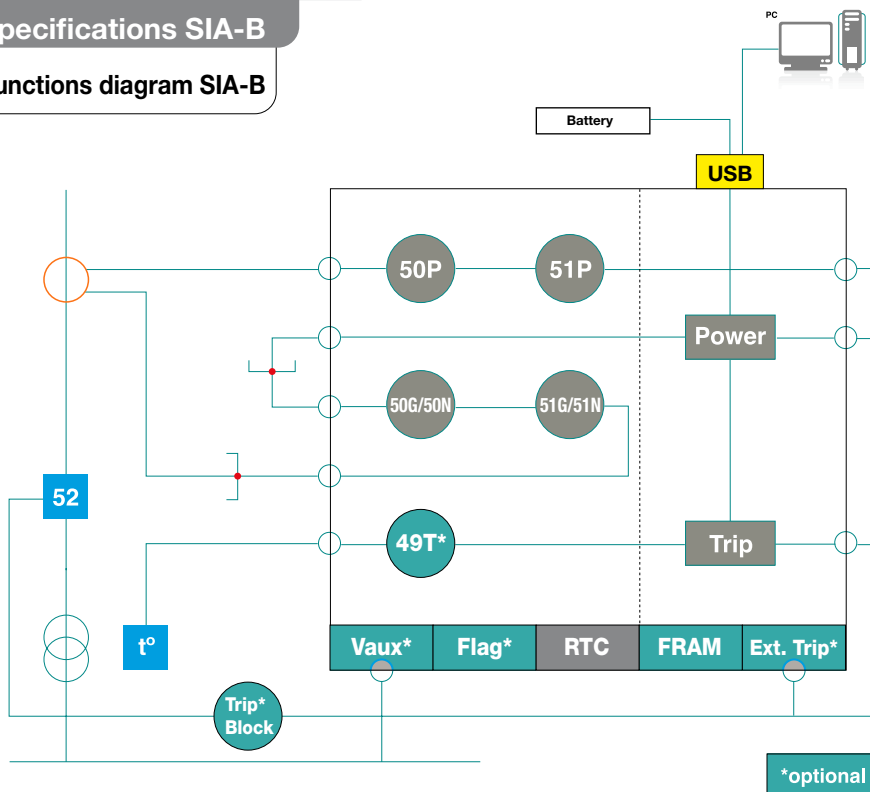

- 3 CT power supply-measurement
- 1 CT sensitive neutral
- Striker

Connections diagram SIA-B

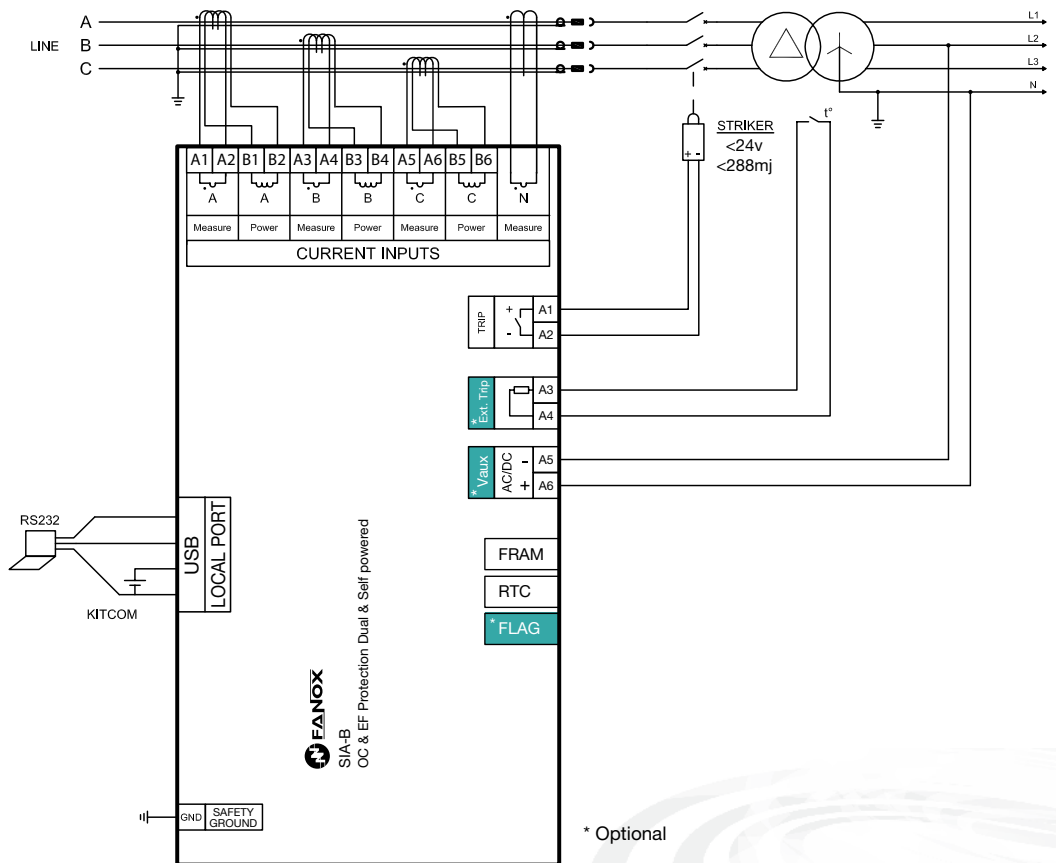

Technical specifications

Technical parameters SIA-B

Function 50P	Permission: yes/no
	Operating range: 0.10 to 30 x I _n (step 0.01)
	Operating time: 0.02 to 300 s (step 0.01)
	Activation level 100%
	Deactivation level 95%
	Instantaneous deactivation

Function 51P	Permission: yes/no
	Operating range: 0.10 to 7 x I _n (step 0,01)
	Curves: IEC 60255-151
	Operating time: Inverse curve, very inverse curve, extremely inverse curve. Definite time: 0.02 to 300 s (step 0.01 s)
	Dial: 0.05 to 1.25
	Curve, activation level 110%
	Curve, deactivation level 100%
	Definite time, activation level 100%
	Definite time, deactivation level 95%
	Instantaneous deactivation
	Timing accuracy: 5% or 30 ms (greater of both)

Function 49T	Charging time 10 s (optional)
Trip blocking	Switch disconnector protection using trip blocking
Trip output	24 Vdc - 288 mJ (activation of the striker or low powered coil)
Frequency	50/60Hz
Current measure	True RMS
	Sampling: 16 samples/cycle Accuracy ±2% over band of ±20% of rated current and ±4% over the rest of the range.
Communication	USB port: Modbus RTU
Auxiliary supply	230 Vac ±20 % / 110 Vdc ±20% / 24 Vdc ±20% (optional)

Function 50N/50G	Permission: yes/no
	Operating range: 0.10 to 30 x I _n (step 0.01)
	Operating time: 0.02 to 300 s (step 0.01)
	Activation level 100%
	Deactivation level 95%
	Instantaneous deactivation

Function 51N/50G	Permission: yes/no
	Operating range: 0.10 to 7 x I _n (step 0,01)
	Curves: IEC 60255-151
	Operating time: Inverse curve, very inverse curve, extremely inverse curve. Definite time: 0.02 to 300 s (step 0.01 s)
	Dial: 0.05 - 1.25
	Curve, activation level 110%
	Curve, deactivation level 100%
	Definite time, activation level 100%
	Definite time, deactivation level 95%
	Instantaneous deactivation
	Timing accuracy: 5% or 30 ms (greater of both)

External battery	With USB KITCOM adapter
Self power from current	Three phase self-power level: I > 0.4 Is
Environment	Operating temperature: -10 to 70 °C
	Storage temperature: -20 to 80 °C
	Humidity: 95%
Transformers	Power supply and measurement 3 specific CT's
Mechanical features	Metallic box
	Panel mounting
	1/4 Rack - 4 U IP-54 panel mounted

Dimensions and cutout SIA-B

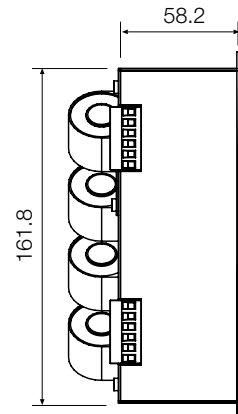
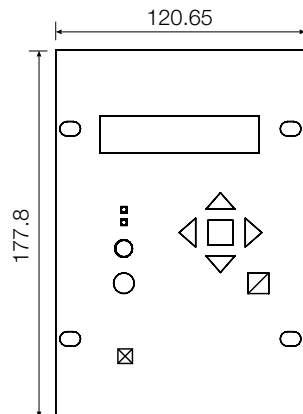

Model list SIA-B

TYPE	NOMINAL CURRENT	NEUTRAL MEASUREMENT	NET FREQUENCY	POWER SUPPLY	ADDITIONAL FUNCTIONS	COMMUNICATIONS	INPUTS - OUTPUTS	MECHANICS	LANGUAGE	ADAPTATION
SIAB										50P+51P+50G/50N+51G/51N
	1 2 3 4 5 6									< 28 A < 56 A < 112 A < 224 A < 448 A < 896 A
		0								Internal measurement
			5 6							50Hz 60Hz
				0 1 2 3						Self-powered Dual-powered at 230 Vac Dual-powered at 110 Vac Dual-powered at 24 Vdc
					0 B					- Trip Block for switch disconnecter
						0				USB frontal
							0 1			2 led's + trip output (striker) + External trip input (49T) + 1 FLAG
								0		
									A B C D	English, Spanish and German English, Spanish and Turkish English , Spanish and French English , Spanish and Russian
										A -

Note: Common technical specifications and accessories, page 42.

SIA-C

DUAL & SELF POWERED OVERCURRENT AND EARTH FAULT PROTECTION RELAY FOR SECONDARY DISTRIBUTION



Main characteristics

- The SIA-C is a Dual & Self powered overcurrent protection relay using the operating current through three /5 (5VA) or /1 (2.5VA) standard current transformers fitted on the lines. These transformers are also used to obtain current measurements. The equipment can be occasionally supplied by an external battery portable kit (KITCOM).
- The events are recorded and a specific test menu is provided.
- High electromagnetic compatibility.
- The installation and subsequent maintenance of batteries is eliminated. The operating costs of the centre are reduced.
- Both in dual powered and self powered modes, the start-up of the relay from 0.1 times of the nominal current in three phases ensures capacity to trip at low energy levels.
- The line opening mechanism is activated either by means of a striker PRT, operated by the energy supplied by the relay itself, or by a coil using the TCM trip adapter in case it is necessary.
- There are bistable magnetic indicators which indicate the trip cause, maintaining their position even though the relay loses the supply (flags).
- Two different sizes of SIA-C relay available by model list to fulfil all the needs of our customers and make the installation easier.



Technical specifications SIA-C

Functions diagram SIA-C

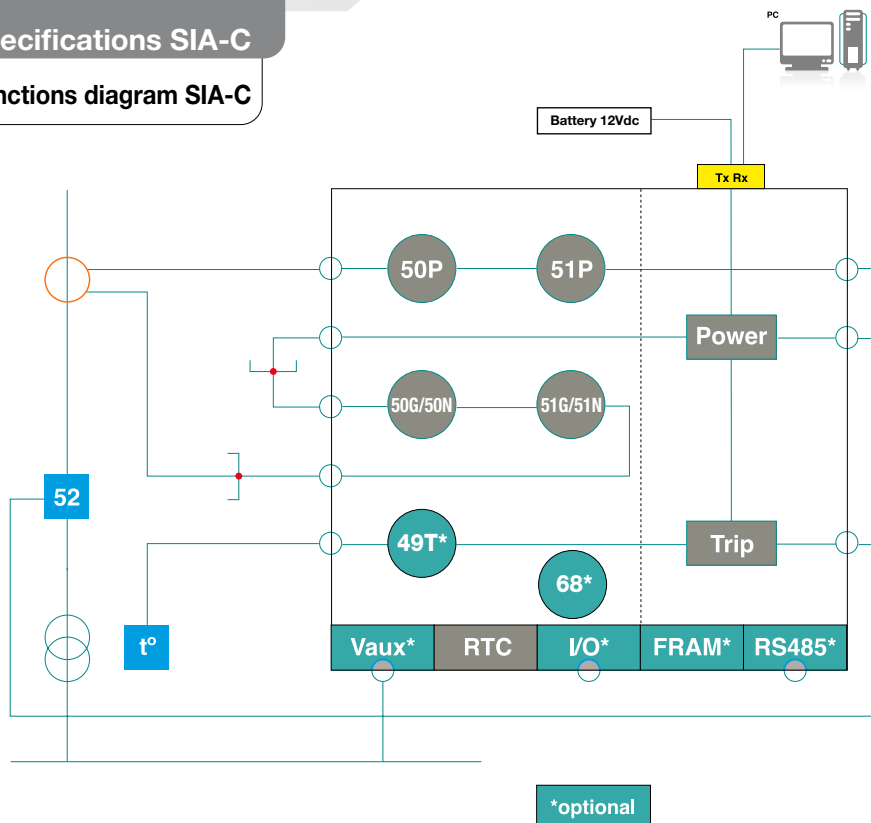

*optional

- 3 CT power supply-measurement
- 1 CT sensitive neutral
- Striker

Connections diagram SIA-C

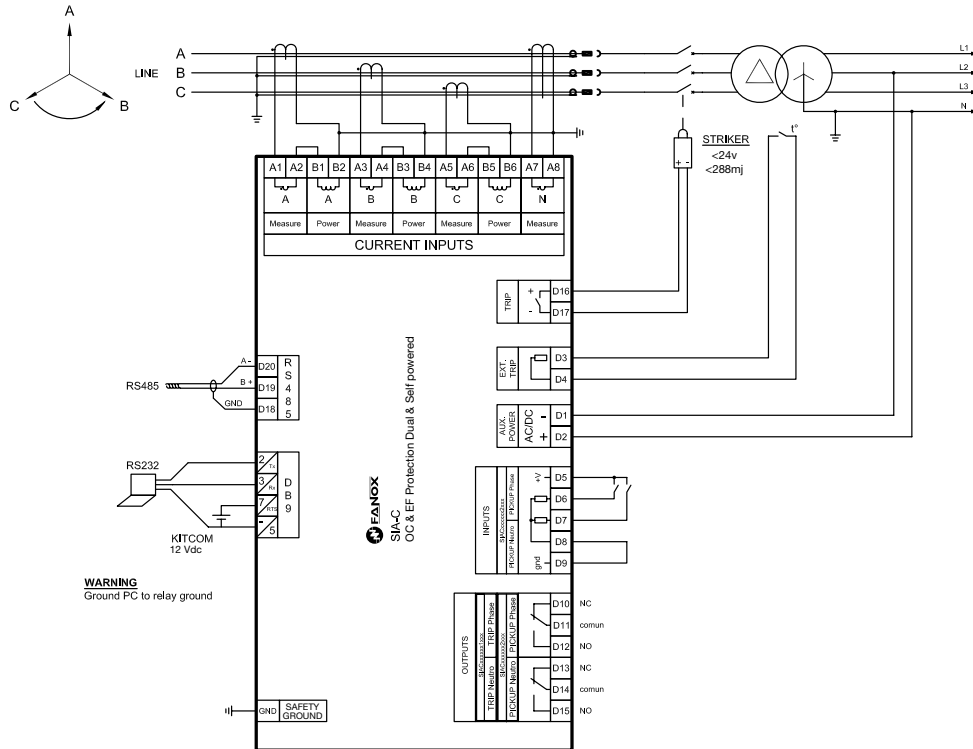

- 3 CT power supply-measurement
- Potential free + TCM

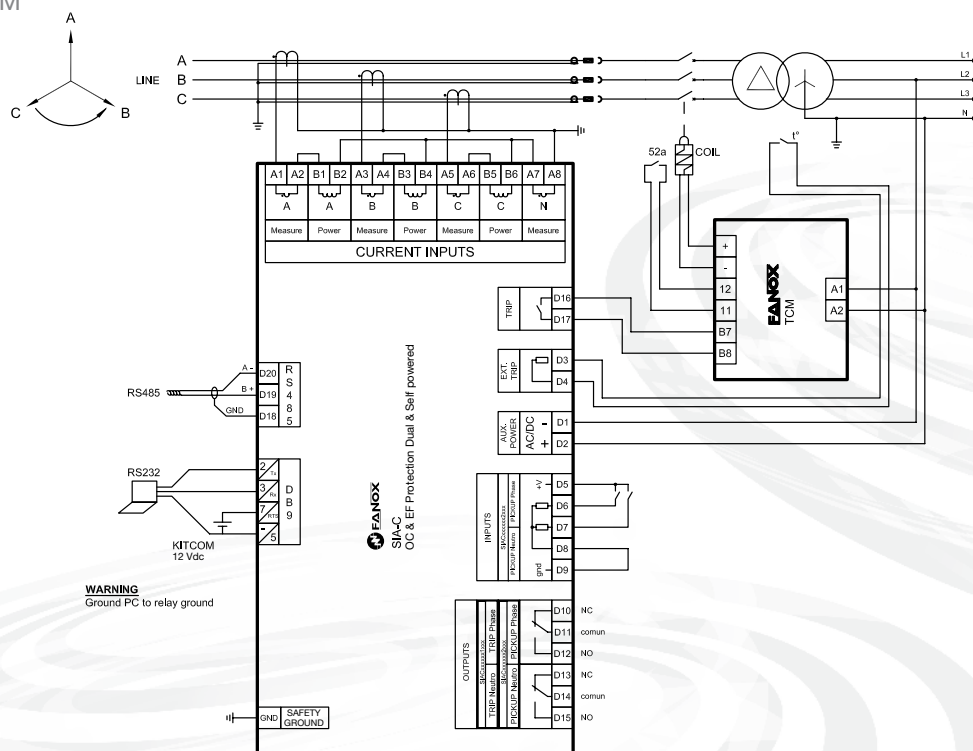

Technical specifications

Technical parameters SIA-C

Function 50P	Permission: yes/no
	Operating range: 0.10 to 30 x I _n (step 0.01)
	Operating time: 0.02 to 300 s (step 0.01)
	Activation level 100%
	Deactivation level 95%
Instantaneous deactivation	

Function 50N	Permission: yes/no
	Operating range: 0.10 to 30 x I _n (step 0.01)
	Operating time: 0.02 to 300 s (step 0.01)
	Activation level 100%
	Deactivation level 95%
Instantaneous deactivation	

Function 51P	Permission: yes/no
	Operating range: 0.10 to 7 x I _n (step 0,01)
	Curves: IEC 60255-151
	Operating time: Inverse curve, very inverse curve, extremely inverse curve. Definite time: 0.02 to 300 s (step 0.01 s)
	Dial: 0.05 to 1.25
	Curve, activation level 110%
	Curve, deactivation level 100%
	Definite time, activation level 100%
	Definite time, deactivation level 95%
	Instantaneous deactivation
	Timing accuracy: 5% or 30 ms (greater of both)

Function 51N	Permission: yes/no
	Operating range: 0.10 to 7 x I _n (step 0,01)
	Curves: IEC 60255-151
	Operating time: Inverse curve, very inverse curve, extremely inverse curve. Definite time: 0.02 to 300 s (step 0.01 s)
	Dial: 0.05 - 1.25
	Curve, activation level 110%
	Curve, deactivation level 100%
	Definite time, activation level 100%
	Definite time, deactivation level 95%
	Instantaneous deactivation
	Timing accuracy: 5% or 30 ms (greater of both)

Function 49T	Charging time 10 s
Trip output	24 Vdc - 288 mJ (activation of the striker or low powered coil) Potential free-contact (for coil trip use TCM)
Frequency	50/60Hz
Current measure	True RMS
	Sampling: 16 samples/cycle Accuracy ±2% over band of ±20% of rated current and ±4% over the rest of the range.
Communication	RS232 port: Modbus RTU
	RS485 port: Modbus RTU
Auxiliary supply	230 Vac ±20 % / 110 Vac ±20% / 24 Vdc ±20%

External battery	With DB9 KITCOM adapter (12 Vdc)
Self power from current	Three phases self-power level: I > 0.1 x I _n
Environment	Operating temperature: -10 to 70 °C
	Storage temperature: -20 to 80 °C
	Humidity: 95%
Transformers	Power supply and measurement 3 standard CT /5 or /1
Mechanical features	Metallic box
	Panel mounting
	1/3 Rack - 4 U or 3/5 Rack - 4 U
	IP-54 panel mounted
Function 68 (Trip Bus)	Blocking permission for 51P, 51P, 50N, 51N

Dimensions and cutout SIA-C

Vertical assembly

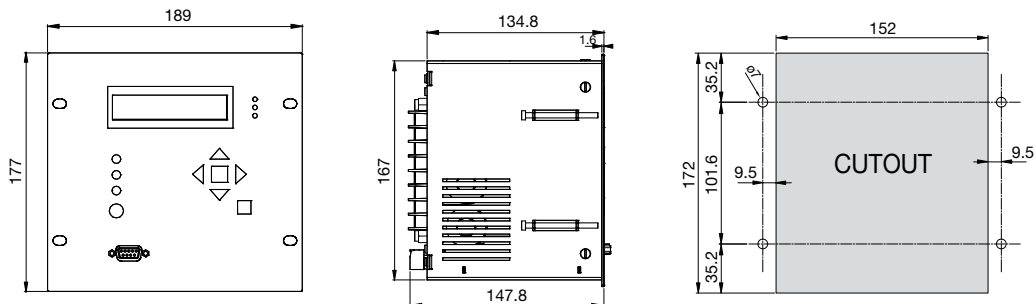

Horizontal assembly

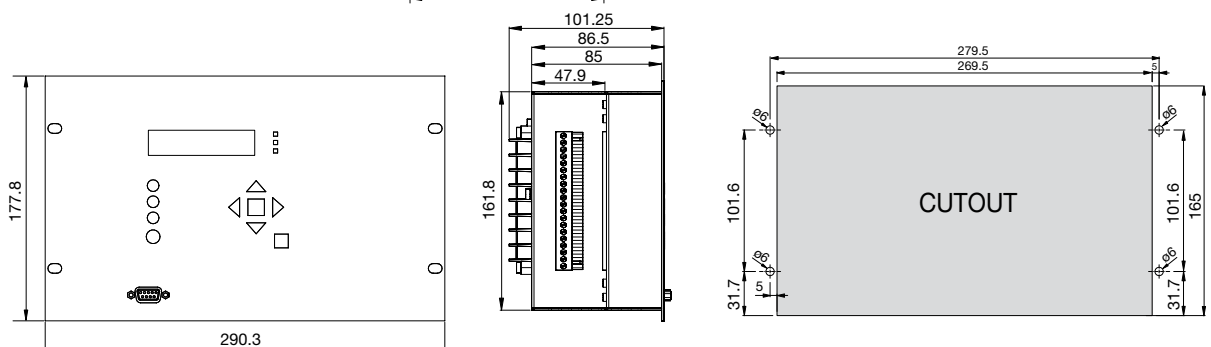

TYPE	PHASE MEASUREMENT	NEUTRAL MEASUREMENT	NET FREQUENCY	POWER SUPPLY	ADDITIONAL FUNCTIONS	COMMUNICATIONS	INPUTS - OUTPUTS	FAST STARTUP & MEMORY	LANGUAGE	MECHANICS	ADAPTATION
SIAC											50P+51P+50N+51N
	1 5										1 A 5 A
		1 5									1 A 5 A
			5 6								50 Hz 60 Hz
				0 1 2 3							Self-powered Self- powered + 230 Vac Self-powered + 110 Vac Self-powered + 24 Vdc
					0 1 2 3 4						For striker For striker and with external trip (49T) For coil For coil and with external trip (49T) For striker and 230 Vac adapted external trip
						0 1					Local ModBus port (RS 232). + Remote ModBus port (RS485).
							0 1 2 3				- 2 outputs to signalling 2 outputs and 2 inputs for Trip Bus function (68) 2 outputs to signalling + 1 output to watchdog
								0 1 2			- non volatile FRAM memory + Fast startup
									A B D		English, Spanish, French and German English, Spanish , French and Turkish English , Spanish , French and Russian
										A B C D E F	Vertical assembly, withdraw able with 3 magnetic Flags Horizontal assembly with 1 magnetic Flag Horizontal assembly with 3 magnetic Flag Vertical assembly with 1 magnetic Flag Vertical assembly with 3 magnetic Flag Vertical assembly with 2 magnetic Flags and handles
											- A - +50P_2+50N_2+3 Settings group

Note: Common technical specifications and accessories, page 42.

SIA-A

DUAL POWERED OVERCURRENT AND EARTH FAULT PROTECTION RELAY FOR SECONDARY DISTRIBUTION

Main specifications

- The SIA-A is a Dual powered overcurrent protection relay using the operating current through specific dual-core current transformers, one used for measuring and the other for powering.
- The events are recorded.
- High electromagnetic compatibility.
- Self power allows for the minimisation of costs for installation and maintenance of the centre as there is no need for batteries or other external power supply items.
- SIA-A starts up from 4 A of primary three phase and 10 A of primary single phase with the relay fully operative at this low energy level.
- Its reduced depth of 60 mm makes it easy to install.
- It includes the switch disconnecter protection function by means of trip blocking.
- The line opening mechanism is activated by means of a striker PRT operated by the energy supplied by the relay itself.
- There are bistable magnetic indicators which indicate the cause of the trip, maintaining their position even though the relay loses the supply (flags).

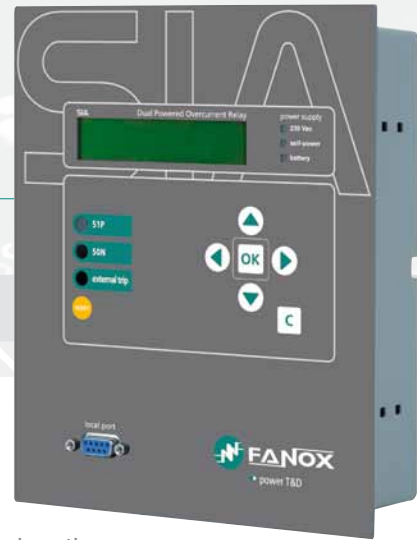

CT-60-100

Highest voltage/Insulation rating:
0.72 kV/3 kV
Insulation class: Class B, 130 °C
Short-circuit thermal intensity/Dynamic:
20 kA - 1 s / 50 kA
Dual Core

SIA-E

WITH ADDITIONAL FEATURES REGARDING TO SIA-A MODEL

Additional specifications

- It can be powered up from 2 A of primary three phase current.
- It includes 50P and 51N protection functions.
- It has Neutral input, getting higher sensibility.
- It is provided with Multilanguage menu (English/Spanish/French) and optional Real Time Clock (RTC).
- It is available with remote communication through RS-485 port and Modbus RTU protocol.
- It has different dimensions.



CT-35-60
CT-60-100

Highest voltage/Insulation rating:
0.72 kV/3 kV
Insulation class: Class B, 130 °C
Short-circuit thermal intensity/Dynamic:
20 kA - 1 s / 50 kA
Dual Core

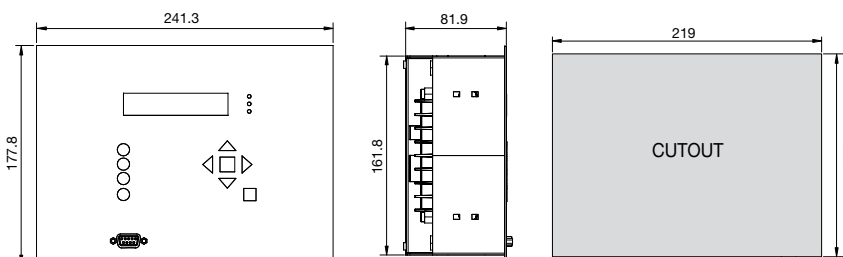

Technical specifications SIA-A

Connections diagram SIA-A

- 3 CT measurement
- 3 CT power supply
- Dual Core CT

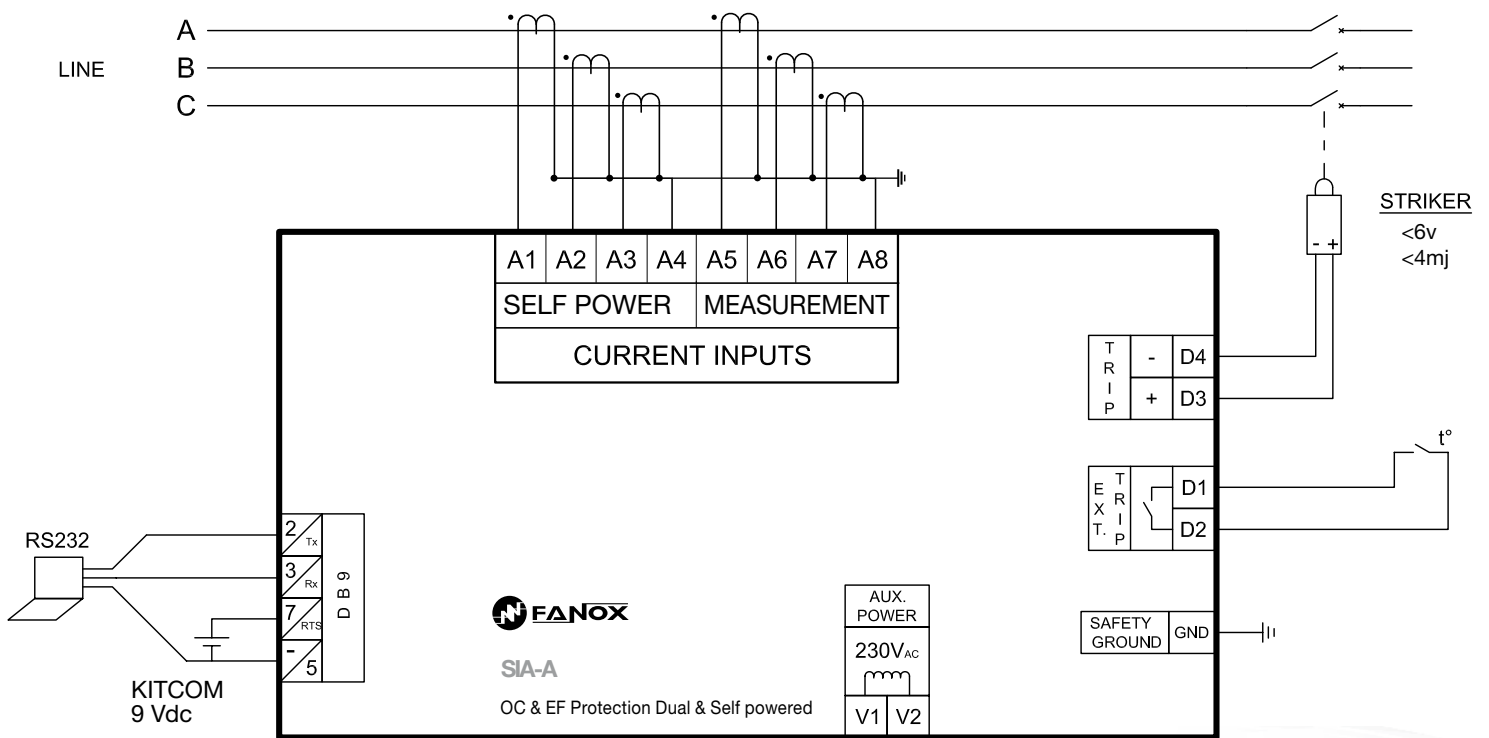

WARNING
Ground PC to relay ground

Technical specifications SIA-A

Functions diagram SIA-A

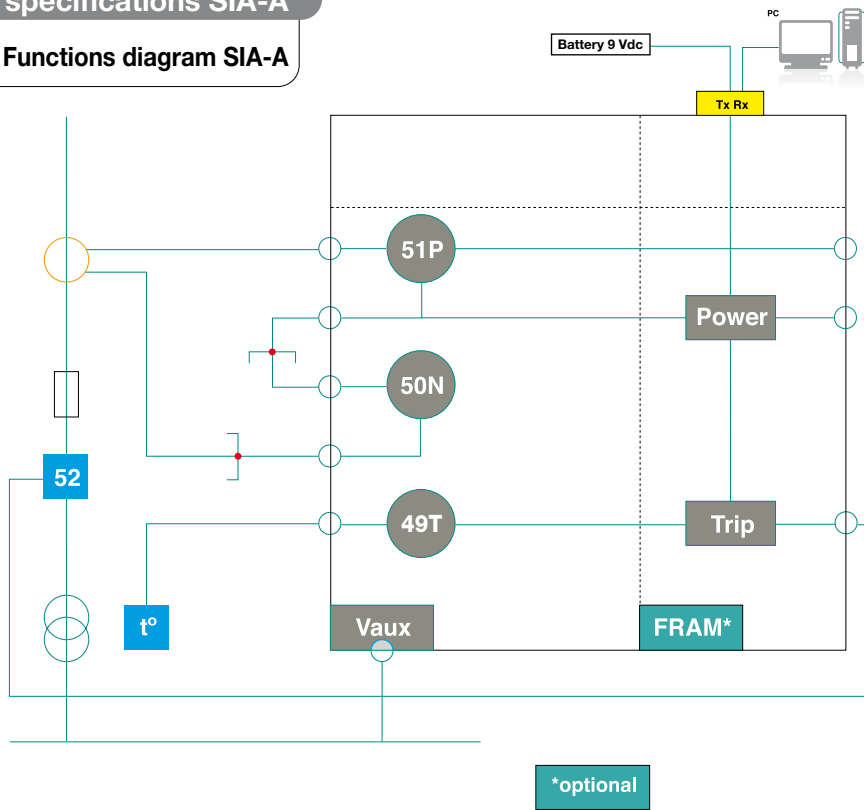

Technical parameters SIA-A

Function 51P	Permission: yes/no
	Operating range: 3 to 100A primary (step 0.01)
	Curves: IEC 60255-151
	Operating time: Inverse curve, very inverse curve, extremely inverse curve.
	Dial: 0.05 to 1.25
	Curve, activation level 120%
	Curve, deactivation level 100%
	Instantaneous deactivation
	Timing accuracy: 5% or 30 ms (greater of both)

Trip blocking	Blocking level: 300 A or 20 x 51P tap (lower of both)
Overtemperature trip input	Charging time 10 s
Trip output	6 V - 4 mJ (activation of the strike)
Frequency	50/60 Hz
Current measure	True RMS
	Sampling: 16 samples/cycle
	Accuracy $\pm 2\%$ over band of $\pm 20\%$ of rated current and $\pm 4\%$ over the rest of the range.
Communications	RS232 port: Modbus RTU

Function 50N	Permission: yes/no
	Operating range: 0.5 to 20 A primary (step 0.1)
	Operating time: 0.02 to 300 s (step 0.01)
	Activation level 100%
	Deactivation level 95%
Instantaneous deactivation	

External battery	With DB9 KITCOM adapter (9 Vdc)
Self power from current	3 phase self-power level $I > 4$ A (primary)
Maximum permanent current	200 A primary
Environment	Operating temperature: -10 to 70 °C
	Storage temperature: -20 to 80 °C
	Humidity: 95%
Transformers	Power supply and measurement. Transformers with double core CT-DB
Mechanical features	Metallic box
	Panel mounting
	160 x 202 x 60 mm
	IP-54 panel mounted
Auxiliary Supply	230 Vac ± 20 %

Model list SIA-A

	TYPE	APPLICATION	FREQUENCY	EVENTS	LANGUAGE	POWER SUPPLY	ADAPTATION
SIA							
	A						50N + 51P + 49T
		R					Switch disconnecter
			5 6				50 Hz 60 Hz
				0 1			With standard RAM memory (events) With non-volatile RAM memory (events)
					S E		Spanish English
						4	Self powered + 230 Vac + 9 Vdc
							A

Note: Common technical specifications and accessories, page 42.

Dimensions and cutout pattern SIA-A

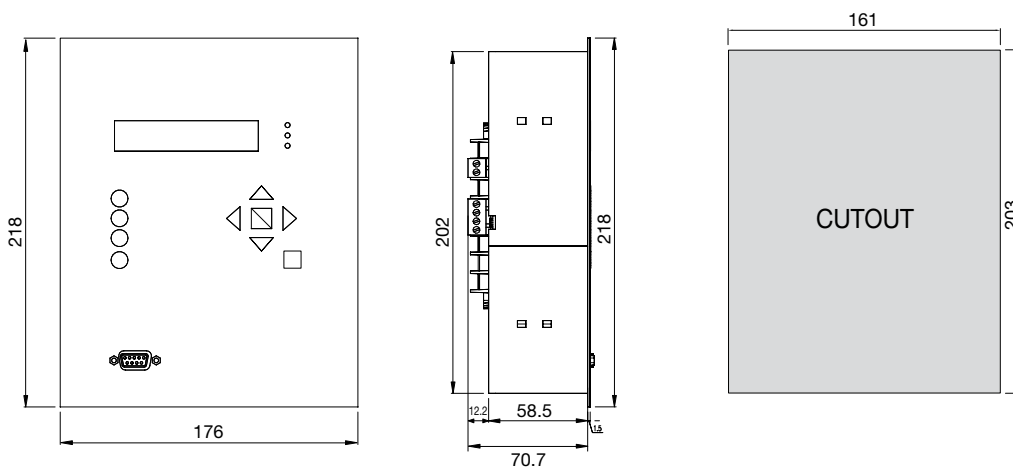

SIA-F

OVERCURRENT AND EARTH FAULT PROTECTION RELAY FOR SECONDARY DISTRIBUTION

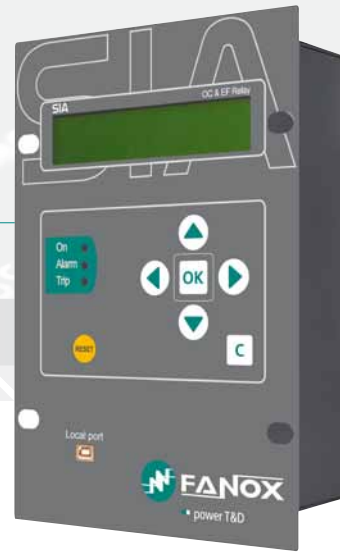

Main specifications

- The SIA-F is an overcurrent protection relay with a switched auxiliary power supply (110-230 Vac / 90-300 Vdc or 24-48 Vdc). The current is measured by using /5 or /1 current transformers.
- 50P, 51P, 50N, 51N, 50G, 51G, 49T protection functions.
- The events are recorded and a specific test menu is provided.
- High electromagnetic compatibility.
- Trip block for switch disconnecter.
- With circuit breaker control and monitoring (circuit breaker status, number of openings, accumulated amperes, etc.).
- Compact size with reduced depth.
- Low power consumption (0,5 W, 24 Vdc).
- Non-volatile RAM memory in order to store up to 100 events.
- USB connection on the front (Modbus RTU communication protocol).
- Possibility of external battery power supply (KITCOM).
- Programmable logic (PLC)

Technical specifications

Functions diagram SIA-F

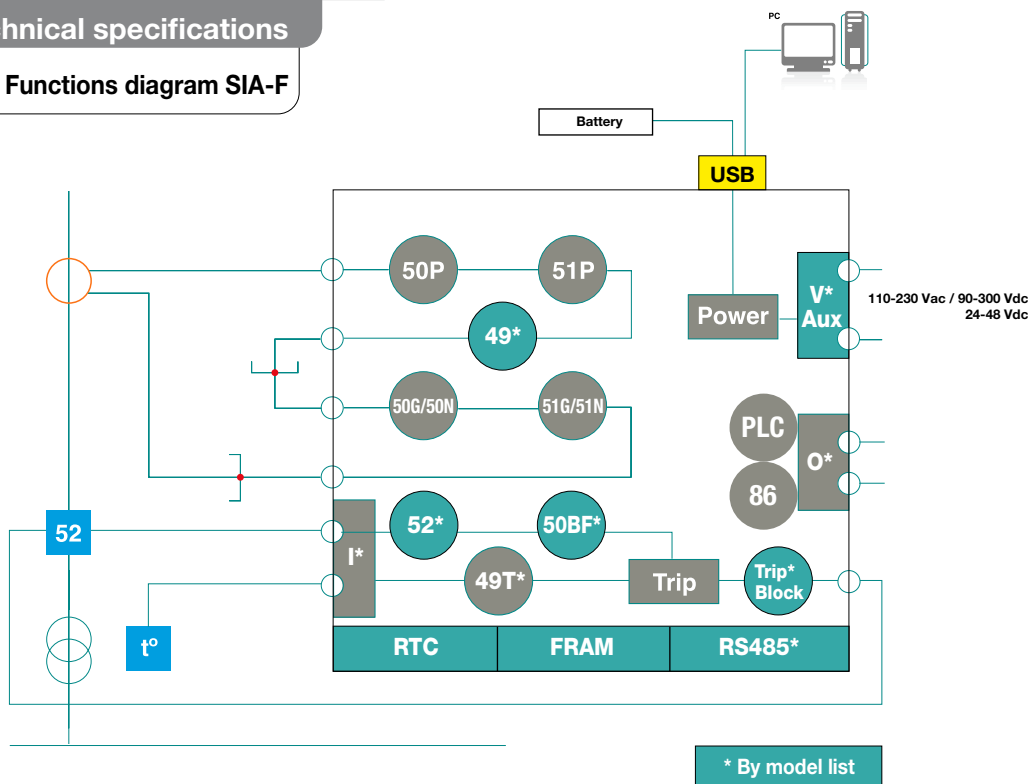

- 3 CT power supply-measurement
- 1 CT sensitive neutral

Connections diagram SIA-F

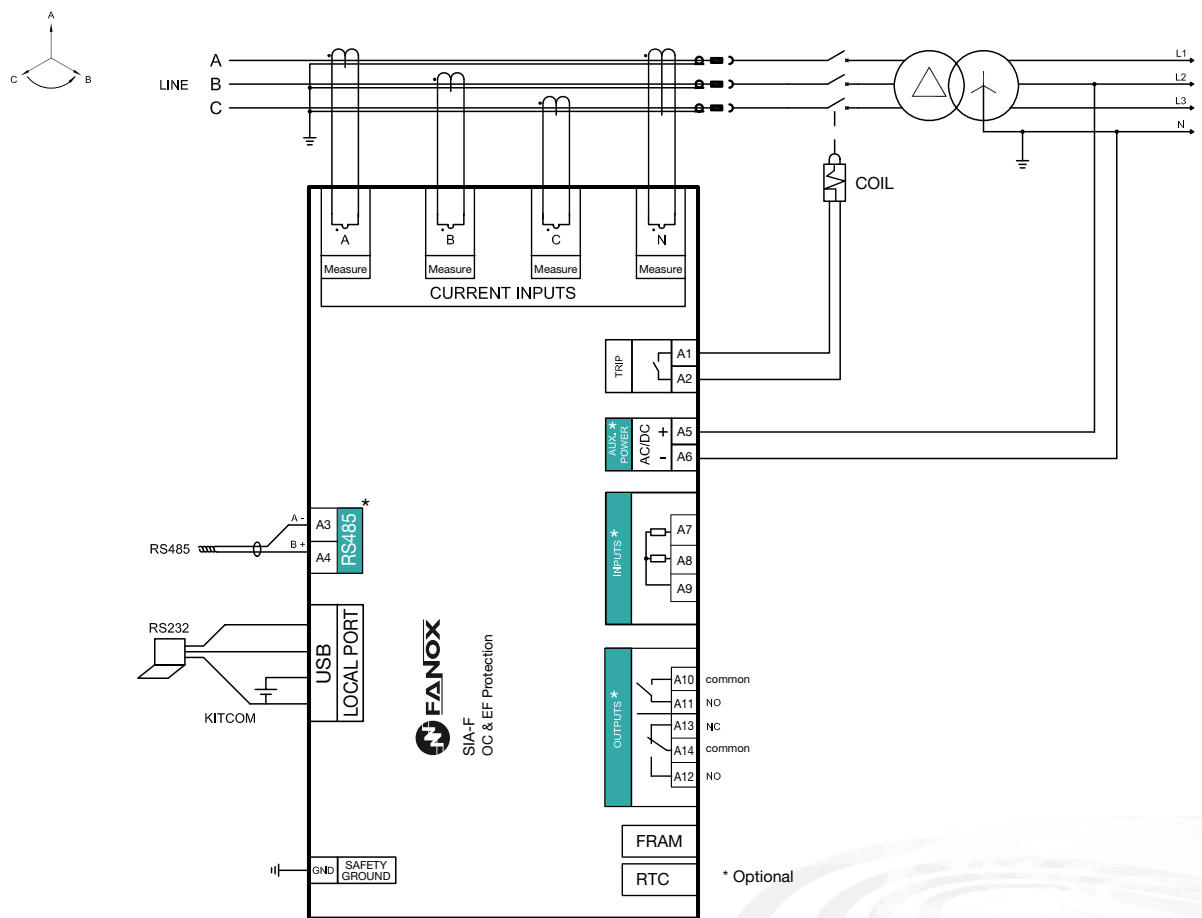

Technical specifications

Technical parameters SIA-F

Function 50P	Permission: yes/no
	Operating range: 0.10 to 30 x In (step 0,01)
	Operating time: 0.02 to 300 s (step 0,01)
	Activation level 100%
	Deactivation level 95%
	Instantaneous deactivation
	Timing accuracy: 30 ms
Function 50N/50G	Permission: yes/no
	Operating range: 0.10 to 30 x In (step 0,01)
	Operating time: 0.02 to 300 s (step 0,01)
	Activation level 100%
	Deactivation level 95%
	Instantaneous deactivation
	Timing accuracy: 30 ms
Function 51P	Permission: yes/no
	Operating range: 0.10 to 7 x In (step 0,01)
	Curves: IEC 60255-151
	Operating time: inverse curve, very inverse curve, extremely inverse curve. Defined time: 0,02 to 300 s (step 0,01 s)
	Dial: 0.05 to 1.25
	Curve, activation level 110%
	Curve, deactivation level 100%
	Defined time, activation level 100%
	Defined time, deactivation level 95%
	Instantaneous deactivation
Timing accuracy: 5% or 30 ms (greater of both)	
Function 51N/51G	Permission: yes/no
	Operating range: 0.10 to 7 x In (step 0.01)
	Curves: IEC 60255-151
	Operating time: inverse curve, very inverse curve, extremely inverse curve. Defined time: 0.02 to 300 s (step 0.01 s)
	Dial: 0.05 to 1.25
	Curve, activation level 110%
	Curve, deactivation level 100%
	Defined time, activation level 100%
	Defined time, deactivation level 95%
	Instantaneous deactivation
Timing accuracy: 5% or 30 ms (greater of both)	
Trip blocking	Blocking level: 1.5 to 20 x In (step 0.01)

Circuit breaker monitoring	Circuit Breaker state: start, open, closed, error, opening time, opening error, closing time, closing error
	Input 52a and/or input 52b
	Opening and closing command
	Alarm, maximum number of openings: 1 a 10000
	Alarm, accumulated amps: 0 a 100000 M(A²)
	Excessive repeated openings: 1 a 10000
	Time of excessive repeated openings: 1 a 300 min
Function 50BF	Function permission : yes/no
	Opening failure time: 0.02 to 1.00 s (step 0.01 s)
	Open breaker activation threshold: 8% In
	Open breaker reset time: 10% In
Function 49	Function permission : yes/no
	Tap: 0.10 a 2.40 Inominal (step 0.01)
	ζ heating: 3 a 600 minutes (step 1)
	ζ cooling: 1 a 6 x ζ heating (step 1)
	Alarm level: 20 a 99% (step 1)
	Trip level: 100%
Programmable Logic Control (PLC)	Trip reset: 95% of alarm level
	Timing accuracy: ± 5% regarding theatrical value
Function 86	OR4, OR4_LACTH, OR4_PULSES, NOR4, NOR4_LACTH, AND4, AND4_PULSES, NAND4
Function 86	Allows to latch (lock out) the contact trip due to programmable logic (PLC).
2 inputs configurable	The same voltage as auxiliary power supply
Frequency	50/60Hz
Current measure	True RMS
	Sampling: 16 samples/cycle
	Accuracy of ±2% in a band of 20% over the rated current and ±4% for the rest of measurement range
Communications	USB port: Modbus RTU
	RS485 port: Modbus RTU
Auxiliary power supply	110-230 Vac / 90-300 Vdc ±20%
	24-48 Vdc ±20%
External battery	With USB KITCOM adapter
Environment	Operating temperature: -10 to 70°C
	Storage temperature: -20 to 80 °C
	Humidity: 95%
Transformers	3 or 4 standard CT /5, /1 or /0.2
Mechanical features	Metallic box
	Panel Mounting
	1/4 Rack – 4 U
	Fondo: 74,6 mm
	IP-54 on panel

Dimensions and cutout SIA-F

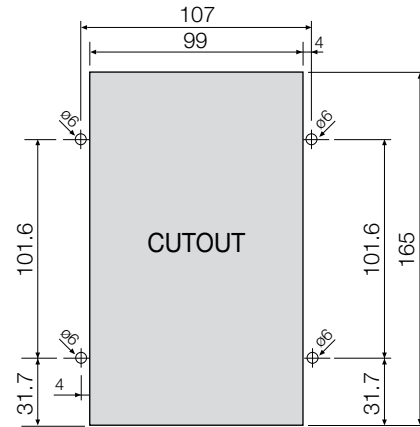
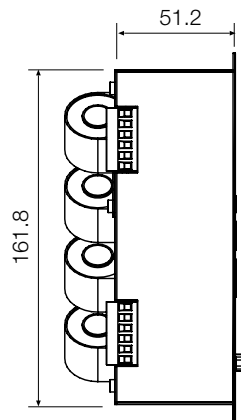
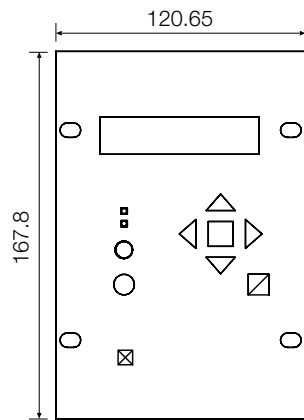

Model list SIA-F

TYPE	PHASE MEASUREMENT	NEUTRAL MEASUREMENT	NET FREQUENCY	POWER SUPPLY	ADDITIONAL FUNCTIONS	COMMUNICATIONS	INPUTS - OUTPUTS	MECHANICS	LANGUAGE	ADAPTATION
SIAF										50P+51P+50G/50N+51G/51N+86+PLC
	1 5									1 A 5 A
		1 5 B								1 A 5 A 0,2 A
			5 6							50Hz 60Hz
				A B						24-48 Vdc 90-300 Vdc / 110-230 Vac
					0 1 B C					- +52+50BF+49 + Trip Block for switch disconnecter + Trip Block for switch disconnecter +52+ 50BF +49
						0 1				USB frontal + rear RS485
							0 1			3 led's + trip output + 2 input + 2 output (configurable)
								0		
									A B C D	English, Spanish and German English, Spanish and Turkish English , Spanish and French English , Spanish and Russian
									A	-

Note: Common technical specifications and accessories, page 42.

SIA-D

OVERCURRENT AND EARTH FAULT PROTECTION RELAY FOR SECONDARY DISTRIBUTION



Main specifications

- The SIA-D is an overcurrent protection relay with a switched auxiliary power supply (110-230 Vac / 90-300 Vdc or 24-48 Vdc). The current is measured by using /5 or /1 current transformers.
- The events are recorded and a specific test menu is provided.
- High electromagnetic compatibility.
- Its reduced depth of 75 mm makes it easy to install.
- It is ideal for transformation and distribution centres with auxiliary power supplies and/or rechargeable batteries.
- It is fitted with two 67N neutral directional units.
- With circuit breaker control and monitoring (circuit breaker status, number of openings, accumulated amperes, etc.)
- It has 4 inputs and 4 free-potential outputs configuration.
- Oscillography records are available.

Technical specifications

Functions diagram SIA-D

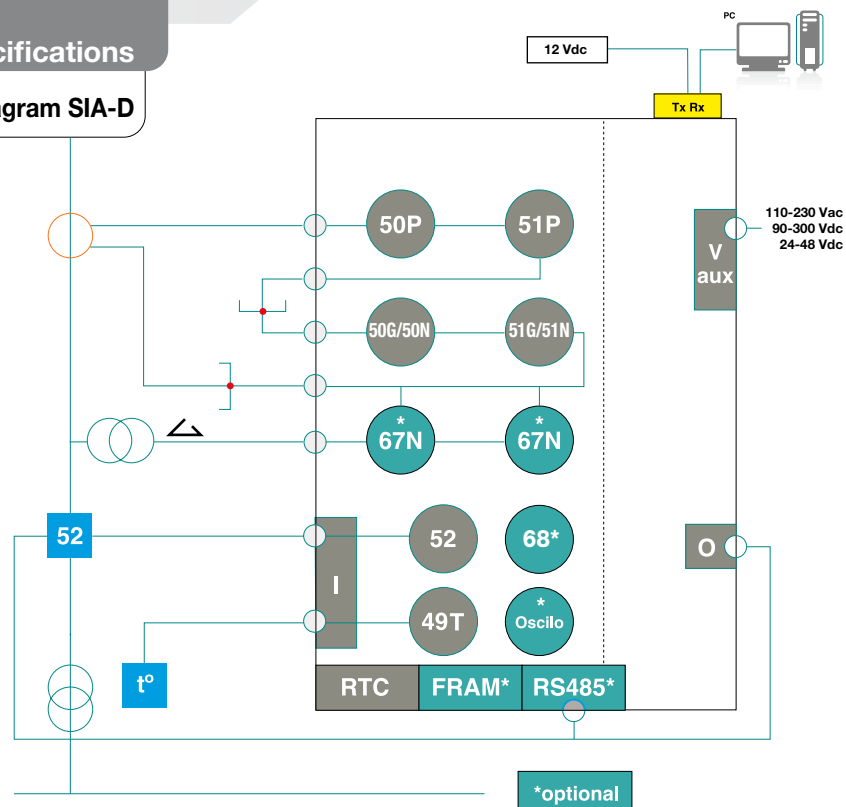

- 3 CT measurement
- 1 CT sensitive neutral
- 1 neutral voltage

Connections diagram SIA-D

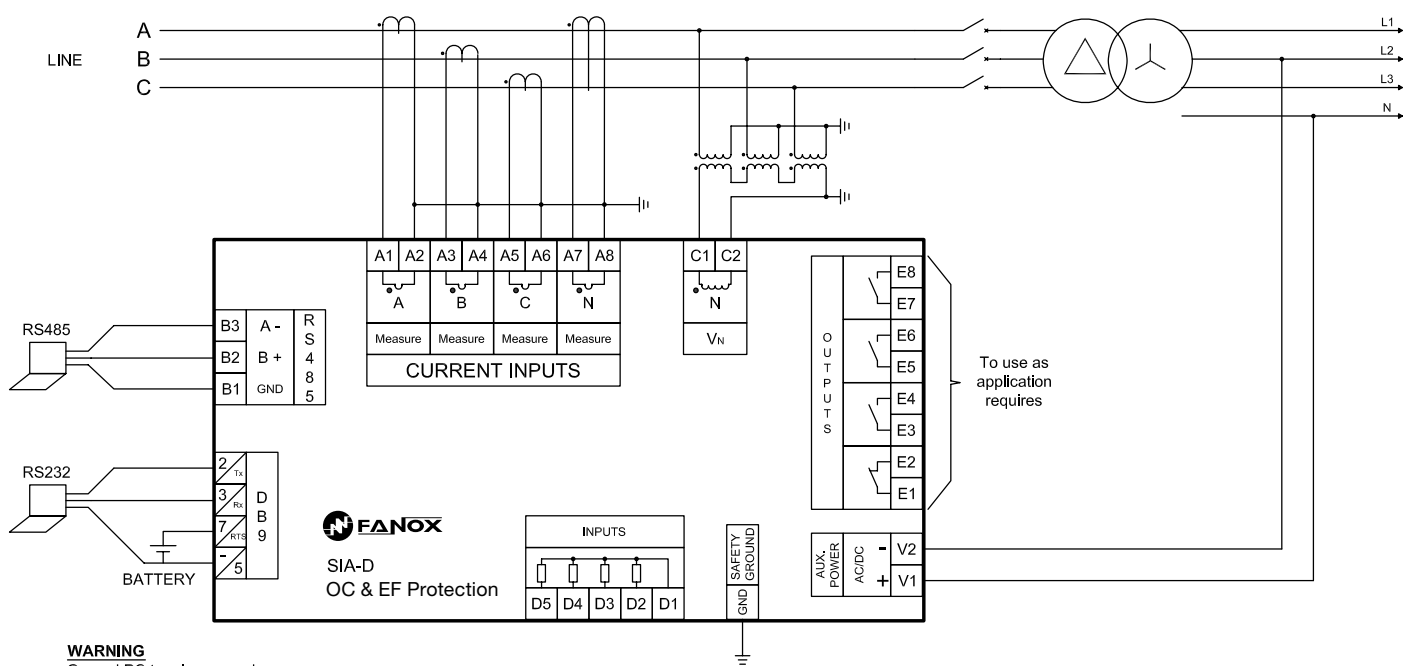

WARNING
Ground PC to relay ground

Technical specifications SIA-D

Technical parameters

Function 50P	Permission: yes/no
	Operating range: 0.10 to 30 x In (step 0.01)
	Operating time: 0.02 to 300 s (step 0.01)
	Activation level 100%
	Deactivation level 95%
Instantaneous deactivation	

Function 50N	Permission: yes/no
	Operating range: 0.10 to 30 x In (step 0.01)
	Operating time: 0.02 to 300 s (step 0.01)
	Activation level 100%
	Deactivation level 95%
Instantaneous deactivation	

Function 51P	Permission: yes/no
	Operating range: 0.10 to 7 x In (step 0.01)
	Curves: IEC 60255-151
	Operating time: Inverse curve, very inverse curve, extremely inverse curve. Definite time: 0.02 to 300 s (step 0.01 s)
	Dial: 0.05 to 1.25
	Curve, activation level 110%
	Curve, deactivation level 100%
	Definite time, activation level 100%
	Definite time, deactivation level 95%
	Instantaneous deactivation
	Timing accuracy: 5% or 30 ms (greater of both)

Function 51N	Permission: yes/no
	Operating range: 0.10 to 7 x In (step 0.01)
	Curves: IEC 60255-151
	Operating time: Inverse curve, very inverse curve, extremely inverse curve. Definite time: 0.02 to 300 s (step 0.01 s)
	Dial: 0.05 to 1.25
	Curve, activation level 110%
	Curve, deactivation level 100%
	Definite time, activation level 100%
	Definite time, deactivation level 95%
	Instantaneous deactivation
	Timing accuracy: 5% or 30 ms (greater of both)

Function 67N (2 units)	Permission: yes/no
	Operating range Io: 0.1 to 30 x In (step 0.01)
	Operating range Vo: 0.4 to 20 V (step 0.1 V)
	Operating time: 0.02 to 300 s (step 0.01 s)
	Directionality: yes/no
	Current, activation level 100%
	Current, deactivation level 95%
	Voltage, activation level 100%
	Voltage, deactivation level 95%
	Operating angle: 0 to 359° (step 1°)
	Semicone angle: 0 to 170° (step 1°)

4 inputs configurables	110 Vdc ±40 % - 0.5 VA
4 outputs configurables	250Vac - 8A 30Vdc - 5A
Trip blocking	Blocking level: 7 to 20 x In (step 0.01)
Function 52 (Breaker monitoring)	Alarm, maximum number of openings: 1 to 2000
	Alarm, maximum number of accumulated amps: 0 to 999.999 (kA²)
Frequency	50/60Hz
Current measure	True RMS
	Sampling: 16 samples/cycle
	Accuracy ±2% over band of ±20% of rated current and ±4% over the rest of the range.
Oscillography	16 records per cycle
	The beginning of the oscillography is configurable 2 registers: 3 cycle previous to the fault and 30 after fault
Function 68 (Trip Bus)	Blocking permission for 50P, 51P, 50N, 51N, 67N1, 67N2

Communications	RS232 port: Modbus RTU
	RS485 port: Modbus RTU
Comnuted supply	110-230 Vac / 90-300 Vdc, ±20 %
Auxiliary supply	24-48 Vdc ±20 %
External battery	With DB9 KITCOM adapter (12 Vdc)
Environment	Operating temperature: -10 to 70 °C
	Storage temperature: -20 to 80 °C
	Humidity: 95%
Transformers	Measurement CT /5 or /1
Mechanical features	Metallic box
	Panel mounting
	1/2 Rack - 4 U
	IP-54 panel mounted

Dimensions and cutout pattern SIA-D

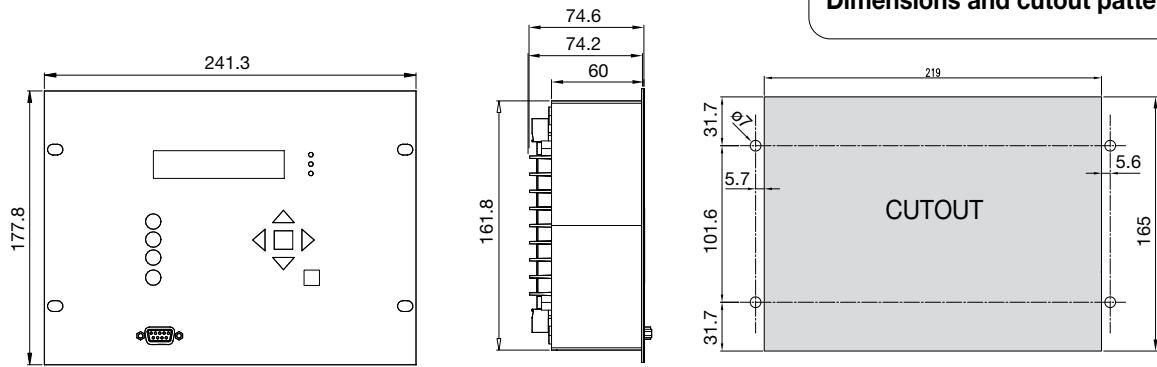

Model list SIA-D

TYPE	PHASE MEASUREMENT	NEUTRAL MEASUREMENT	NET FREQUENCY	POWER SUPPLY	ADDITIONAL FUNCTIONS	COMMUNICATIONS	INPUTS - OUTPUTS	MEMORY	LANGUAGE	ADAPTATION
SIAD										50P+51P+50N+51N+52
	1 5									1 A 5 A
		1 5								1 A 5 A
			5 6 7 8							50 Hz + Trip Block for switch disconnecter 50Hz 60 Hz + Trip Block for switch disconnecter 60 Hz
				2 3						90Vdc – 300Vdc / 110 Vac – 230Vac 24 - 48 Vdc
					0 1					- + 67N1 + 67N2
						0 1				Local ModBus port (RS 232). + Remote ModBus port (RS485).
							2			4 Outputs + 4 Inputs
								0 1 2		- non volatile FRAM memory + Oscillography
									A B D	English, Spanish, French and German English, Spanish , French and Turkish English , Spanish , French and Russian
										A B - + Trip Bus function (68) + USB local port

Note: Common technical specifications and accessories, page 42.

SIL-A

OVERCURRENT AND EARTH FAULT RELAY FOR PRIMARY AND SECONDARY DISTRIBUTION



Main characteristics

- The SIL-A is an overcurrent and earth fault protection relay for primary and secondary distribution with auxiliary power supply (110-230 Vac/ 90-300 Vdc and optionally 24-48 Vdc). The current measurement is obtained either by standard current transformers /1 or /5, or by special low power current transformers (LPCT).
- Metallic box with high electromagnetic compatibility level (EMC) and wide range of operating temperature.
- Its reduced size makes the SIL-A relay easy to install and its light weight helps the customer to save costs in transport.
- Many protection functions: 2x50P, 2x50N, 51P, 51N, 50BF, 46, 52, 79, 74TCS, COLD LOAD PICK-UP. Optionally 49.
- Direct signalling/control both of the circuit breaker (52 function), both of the recloser (79 function).
- Two communication protocols can be used simultaneously:
 - MODBUS RTU protocol
 - IEC 60870-5-103 protocol, optionally IEC 61850, DNP 3.0 and IEC 60870-5-104
To allow the communication relays have a communication port on the front of the equipment and two rear ports on the back for remote communication.
- The SIL-A has 8 configurable inputs and 5 configurable outputs, taking into account that there is another independent one: the trip coil supervision (74TCS function).
- 2 oscillographic records, 20 fault reports and non-volatile RAM memory: stores 500 events with date / time even without power supply thanks to its internal RTC (Real Time Clock).
- Optionally there is a model with external module for measurement collecting of CT's (/1 or /5) including the following advantages:



- The relay can be “unplugged”, what guarantees current circuits remain in short circuit if we disconnect them.
- Passing through secondary circuits, the equipment has not connection terminals, getting a better electric insulation.
- By means of its location on DIN rail, the installation in the switchgear is easier because the module can be located at the bottom of the Low Voltage frame of the switchgear.
- Connection disconnection detection alarm in the relay.
- The relay enables the use of CT's /1 or /5 with different transformation ratios allowing the reduction in number and type of necessary CT's.

Technical specifications SIL-A

Functions diagram SIL-A

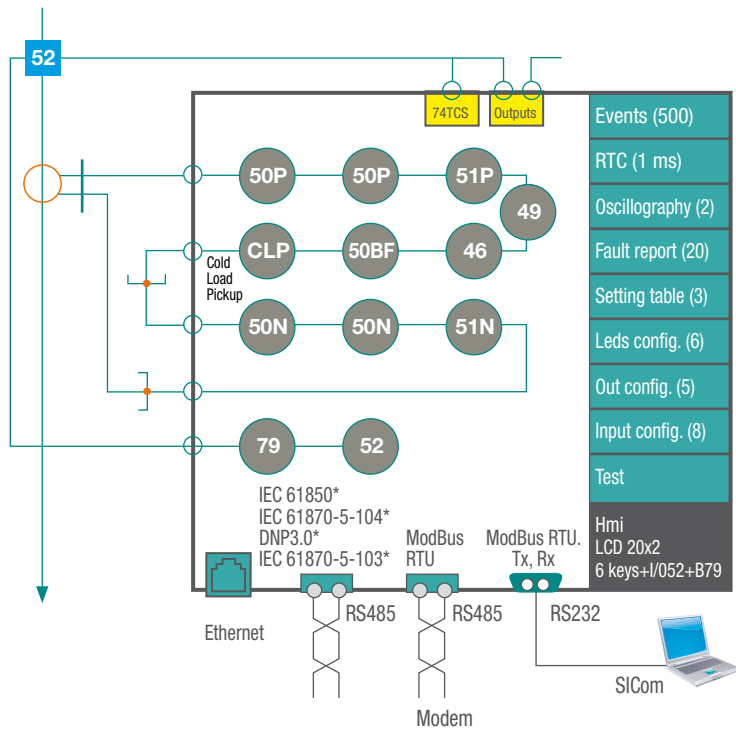

Connections diagram SIL-A

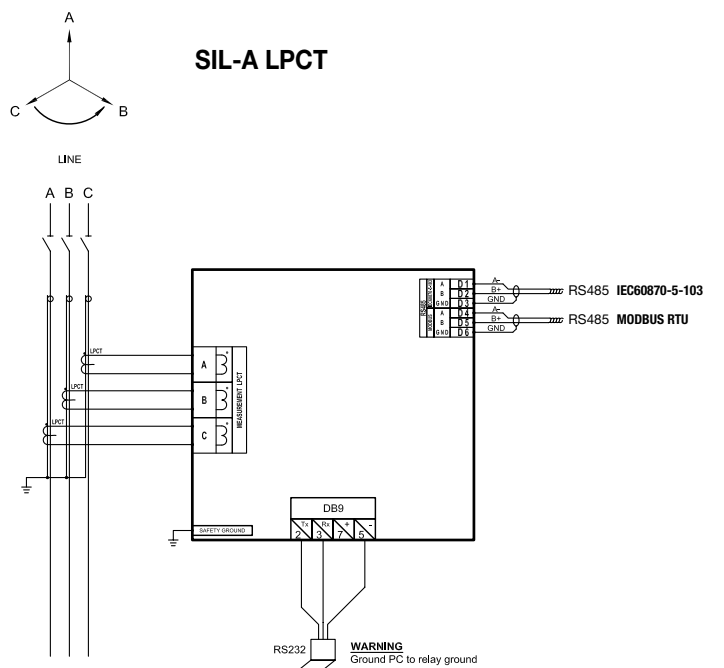
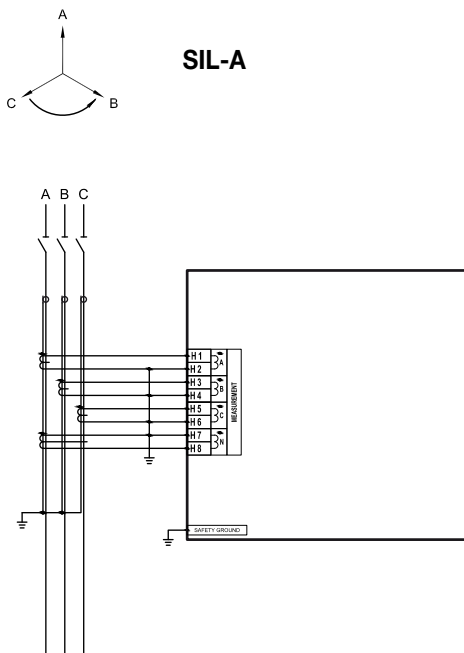

Technical specifications

Technical parameters SIL-A

50P_1 50P_2	Function permission: Yes/no
	Operating range: 0.10 to 30 xIn (step 0.01)
	Operating time: 0.02 to 300 s (step 0.01 s)
	Activation level 100%
	Reset level 95%
	Instant reset
50N_1 50N_2	Function permission: Yes/no
	Operating range: 0.10 to 30 xIn (step 0.01)
	Operating time: 0.02 to 300 s (step 0.01 s)
	Activation level 100%
	Reset level 95%
	Instant reset
51P	Function permission: Yes/no
	Operating range: 0.10 to 7 xIn (step 0.01)
	Curves IEC 60255-151 and ANSI
	Operating time: Inverse curve, very inverse curve, extremely inverse curve. Defined time : 0.02 to 300 s (step 0.01 s)
	Dial: 0.05 a 2.20
	Curve activation level 110%
	Curve reset level 100%
	Defined time activation level 100%
	Defined time reset level 95%
	Instant reset
Timer accuracy: 5% or 30 ms (whichever is greater)	
51N	Function permission: Yes/no
	Operating range: 0.10 to 7 xIn (step 0.01)
	Curves IEC 60255-151 and ANSI
	Operating time: Inverse curve, very inverse curve, extremely inverse curve. Defined time : 0.02 to 300 s (step 0.01 s)
	Dial: 0.05 a 2.20
	Curve activation level 110%
	Curve reset level 100%
	Defined time activation level 100%
	Defined time reset level 95%
	Instant reset
Timer accuracy: 5% or 30 ms (whichever is greater)	
46	Function permission: Yes/no
	Operating range: 0.10 to 1,00 xIn (step 0.01)
	Operating time: 0.02 to 300 s (step 0.01 s)
	Activation level: 100%
	Reset level 95%
	Instant reset
49	Function permission: Yes/no
	Operating range: 0.1 to 2,4 xIn (step 0.01)
	ζ heating: 3 to 600 min (step 1)
	ζ cooling: 1 to 6 ζ heating (step 1)
	Alarm: 20 to 99 % (step 1)
	Trip level: 100%
	Trip reset: 95% of alarm level
	Trip time accuracy: ± 5% over the theoretic.
Trip time curves are valid under 20 times the adjusted tap. With currents higher than 20 times the adjusted tap, trip time and thermal image value are truncated to 20 times the adjusted tap.	
Circuit breaker monitoring	Circuit breaker status: Pickup, open, closed, error, opening time, opening fault, closing time and closing fault.
	Input 52a and/or input 52b
	Open and close command
	Alarm for maximum opening number: 1 to 10000
	Alarm for accumulated amps: 0 to 100000 (M(A²))
	Maximum repeated openings: 1 to 10000
	Time of maximum repeated openings: 1 to 300 min

50BF	Function permission: Yes/no
	Opening fault time: 0.02 to 1.00 s (step 0.01 s)
	Open circuit breaker activation threshold: 8% In
	Open circuit breaker reset threshold: 10% In
	Function Pickup: Equipment trip, activation of the opening fault input, circuit breaker open control activation.
79	Function Permission: yes/no
	Hold permission: si/no
	Number of reclosings: 1 a 5
	Reclosing time 1, 2, 3, 4, 5 : 0,02 a 300,00 s (step 0,01 s)
	Operating time: 0,02 a 300,00 s (step 0,01 s)
	Locking possibilities: pulse inputs, level inputs, commands.
	Replacement time: 0,02 a 300,00 s (step 0,01 s)
Definitive opening time: 0,02 a 300,00 s (step 0,01 s)	
74TCS	Function permission: yes/no
	Operating time: 0.02 to 300 s (step 0.01 s)
	Control voltage presence: -40%
	Trip continuity, in circuits A and B
CLP	Function permission: Yes/no
	50P_1 Multiplier range: 1 to 5
	50P_2 Multiplier range: 1 to 5
	50N_1 Multiplier range: 1 to 5
	50N_2 Multiplier range: 1 to 5
	CLP pass time: 1 to 18000 s (step 1 s)
	CLP duration: 1 to 18000 s (step 1 s)
	CLP activation threshold: 8% In
CLP reset threshold: 10% In	
Settings tables	1 General
	3 Criteria
	Activated, by inputs, by communications, by general settings.
RTC	Capacitor charge time: 10 minutes
	Operation with no auxiliary voltage: 72 hours
Oscillography	16 samples/cycle
	Oscillograph start configuration
	2 records: 3 pre-fault and 47 post-fault cycles
	COMTRADE IEEE C37.111-1991
Fault reports	4 analog channels y 80 digital channels
	20 fault reports with 80 digital channels
8 inputs which can be set	Same voltage as the auxiliary power supply
5 outputs which can be set	250 Vac – 8 A
	30 Vdc – 5 A
Frequency	Output 1 and output 2: NC + NO
	Rest: NO
Current measurement	50/60Hz
	Phase current (IA, IB, IC), neutral (IN) and negative sequence(I2)
	Real RMS
	Sampling: 16 samples/cycle
	±2% Accuracy over a band of ±20% over the nominal current and 4% over the rest of the range
Communications	Local port RS232: ModBus RTU
	Remote port RS485: ModBus RTU
	Remote port RS485 IEC 60870-5-103
	Remote port RJ45: IEC 61850
Auxiliary power	90 Vdc – 300Vdc / 110 Vac – 230 Vac ±20%
	24-48 Vdc ±20%
Environmental conditions	Operating temperature : -10 to 70°C
	Storage temperature: -20 to 80°C
Transformers	Relative humidity: 95%
	Measurement 3 or 4 CT /5 or /1
Mechanical Characteristics	Measurement 3 LPCT (current transformers with voltage output)
	Metallic box
	Panel mounted.
	1/2Rack – 4 U
	IP-54

Dimensions and cutout pattern SIL-A

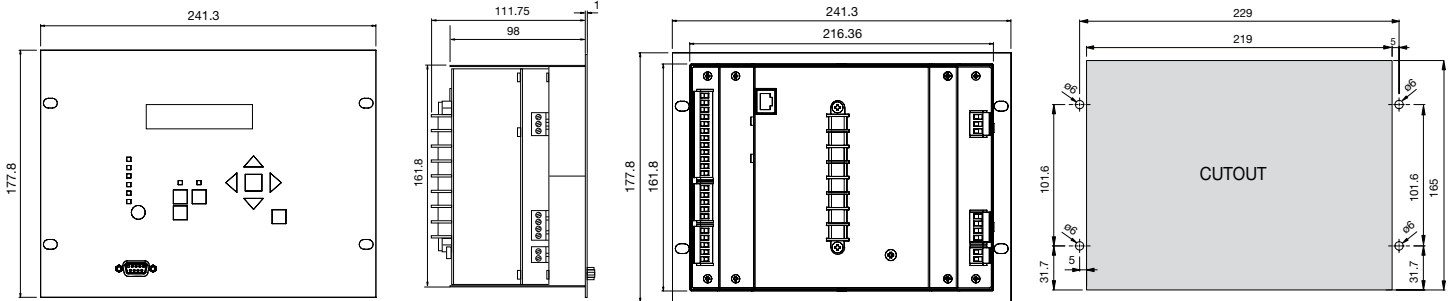

Model list SIL-A

TYPE	PHASE MEASUREMENT	NEUTRAL MEASUREMENT	NET FREQUENCY	POWER SUPPLY	ADDITIONAL FUNCTIONS	COMMUNICATIONS	INPUTS - OUTPUTS	MECHANICS	LANGUAGE	ADAPTATION
SILA										50P1+50P2+51P+50N1+50N2+51N+52+50BF+46+79 +74TCS + Cold Load Pickup
	1 5 X									1 A 5 A LPCT
		1 5 X								1 A 5 A LPCT
			5 6							50 Hz 60 Hz
				A B						24 - 48Vdc 90 - 300Vdc / 110 - 230Vca
					0 1					- +49
						0 1 2 3 4 5				RS485: ModBus + IEC 60870-5-103 FOP: ModBus + IEC 60870-5-103 FOC-ST: ModBus + IEC 60870-5-103 <i>(Only in compact version)</i> IEC61850 + ModBus (RS485) DNP3.0 (TCP/IP) + ModBus (RS485) IEC 60870-5-104 + ModBus (RS485)
							0			5 outputs + 8 inputs
								0 1		With external MMS module: 4U x 1/2 rack Compact: 4U x 1/2 rack
									A D	English, Spanish, French and German English, Spanish, French and Turkish English, Spanish, French and Russian
									A B	- Increase event number to 1,000 & increase oscilo duration to 4.4 seconds

Note: Common technical specifications and accessories, page 42.

SIL-B

FEEDER PROTECTION RELAY FOR PRIMARY DISTRIBUTION



Main characteristics

- The SIL-B is a relay for primary distribution which is able to protect a feeder by means of current and voltage functions. It is normally used with a circuit breaker as cutting element.
- SIL-B is used with auxiliary power supply (110-230 Vac/ 90-300 Vdc and optionally 24-48 Vdc).
- Protection functions available in SIL-B are the following:
50P (2), 50N (2), 67/51/50P (2), 67/51/50N (2), 46, 59P (2), 59N (2), 27P (2), 32/40 (4), 79, 50BF, 52, Cold Load Pick-up and 74TCS.
Optionally: 81 U/O, 25, 37 and IRIG-B.
- 79 protection function (Recloser) allows up to 5 attempts of reclosing which can be programmed by the user.
- SIL-B has metallic box with high electromagnetic compatibility level (EMC) and wide range of operating temperature.
- Its reduced size makes the SIL-B relay easy to install and its light weight helps the customer to save costs in transport.
- Direct signalling/control both of the circuit breaker (52 function), both of the recloser (79 function).
- Two communication protocols can be used simultaneously:
 - MODBUS RTU protocol
 - IEC 60870-5-103 protocol, optionally IEC 61850, DNP 3.0 and IEC 60870-5-104
To allow the communication relays have a communication port on the front of the equipment and two rear ports on the back for remote communication.
- SIL-B can show different measurements like:
 - Phase, Neutral, Positive Sequence and negative sequence currents
 - Phase, Phase-Phase, Neutral and Bar voltages
 - Angles between voltage and current on each phase
 - Active, reactive and apparent power phase and total 3-phase
 - $\cos \varphi$ (3-phase and single phase)
 - Active and Reactive Energy
- The SIL-B has 8 configurable inputs and 7 configurable outputs.
- 2 oscillographic records, 20 fault reports and non-volatile RAM memory: stores 1.000 events with date/time event without power supply thanks to its internal RTC (Real Time Clock).
- Optionally there is a model with a external mms module, where CT's (/1 or /5) are incorporated in order to keep the relay in working order with following advantages:
 - The relay can be "unplugged", what guarantees current circuits remain in short circuit if we disconnect them.
 - Passing through secondary circuits, the equipment has not connection terminals, getting a better electric insulation.
 - By means of its location on DIN rail, the installation in the switchgear is easier because the module can be located at the bottom of the Low Voltage frame of the switchgear.
 - Connection disconnection detection alarm in the relay.
 - The relay enables the use of CT's /1 or /5 with different transformation ratios allowing the reduction in number and type of necessary CT's.

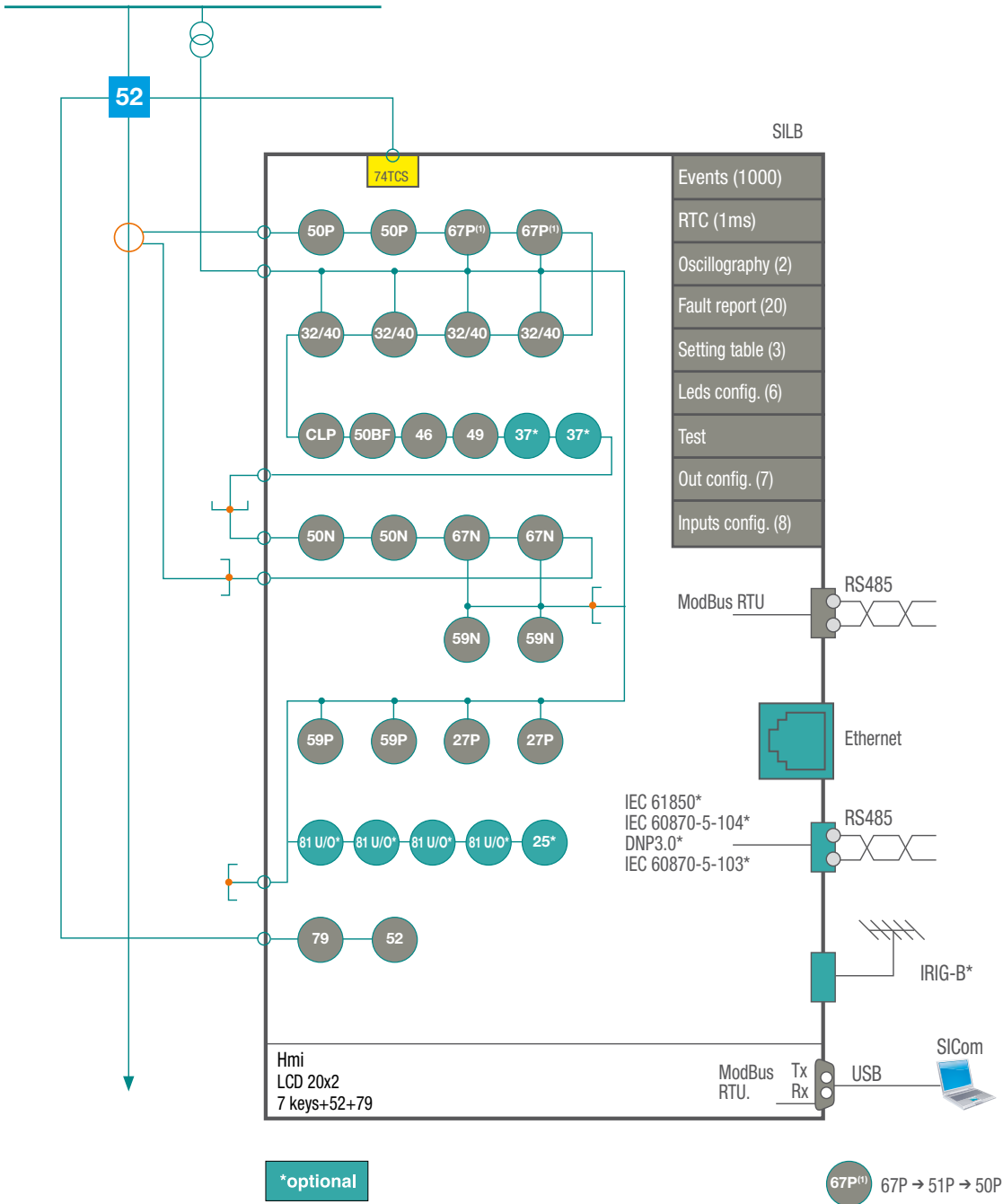

Technical specifications

Technical parameters SIL-B

50P_1 50P_2	Function permission : yes/no	49	Function permission : yes/no
	Operating range: 0.10 to 30 xIn (step 0.01)		Tap: 0.10 a 2.40 Inominal (step 0.01)
	Operating time: 0.02 to 300.00 s (step 0.01 s)		ζ heating: 3 a 600 minutos (step 1)
	Activation level: 100%		ζ cooling: 1 a 6 veces ζ heating (step 1)
	Reset level: 95%		Alarm level: 20 a 99% (step 1)
50N_1 50N_2	Instant reset	59P_1 59P_2	Activation level: 100%
	Function permission : yes/no		Reset level: 95%
	Operating range: 0.10 to 30 xIn (step 0.01)		Timing accuracy: ± 5% respect of theoretical value.
	Operating time: 0.02 to 300.00 s (step 0.01 s)		Function permission : yes/no
	Activation level: 100%		Operating range: 4 to 110V (step 1)
67/51/50P_1 67/51/50P_2	Reset level: 95%	59N_1 59N_2	Operating time: 0.02 to 300.00 s (step 0.01 s)
	Instant reset		Reset time: 0.2 to 1200.0 s (step 0.1)
	Function permission : yes/no		Activation level: 100%
	Operating range I: 0.10 to 7 xIn (step 0.01)		Reset level: 95%
	Operating range V: 4 to 110V (step 1)		Temporized reset
	IEC 60255-151 and ANSI curves	27P_1 27P_2	Accuracy 30ms maximum respect of adjusted time
	Operating time: Inverse curve, very inverse curve, extremely inverse curve. Definite-time: 0.02 to 300.00 s (step 0.01 s)		Function permission : yes/no
	Dial: 0.05 to 2.20 (step 0.01)		Operating range: 4 to 110V (step 1)
	Directionality: yes/no		Operating time: 0.02 to 300.00 s (step 0.01 s)
	Activation level, current with curve: 110%		Reset time: 0.2 to 1200.0 s (step 0.1)
	Reset level, current with curve: 100%	32_1 32_2 32_3 32_4	Activation level: 100%
	Activation level, current with definite-time: 100%		Reset level: 95%
	Reset level, current with definite-time: 95%		Temporized reset
	Voltage activation level: 100%		Accuracy 30ms maximum respect of adjusted time
	Voltage reset level: 95%		Function permission : yes/no
Instant reset	81_1 81_2 81_3 81_4	Operating range: 0 to 10000 VA (step 1) – secondary values	
Timing accuracy: 5% or 30 ms (whichever is higher):		Operating angle: 0 to 359° (step 1°)	
Operating angle: 0 to 359° (step 1°)		Operating time: 0.02 to 300.00 s (step 0.01 s)	
Half cone angle: 0 to 170° (step 1°)		Activation level: 100%	
Function permission : yes/no		Reset level: 95%	
67/51/50N_1 67/51/50N_2	Operating range I: 0.10 to 7 xIn (step 0.01)	Circuit breaker monitoring	Instant reset
	Operating range V: 4 to 110V (step 1)		Function permission : yes/no
	IEC 60255-151 and ANSI curves		Type: Underfrequency or overfrequency
	Operating time: Inverse curve, very inverse curve, extremely inverse curve. Definite-time: 0.02 to 300.00 s (step 0.01 s)		Operating range: 45.00 a 65.00 Hz (step 0.01)
	Dial: 0.05 to 2.20 (step 0.01)		Operating time: 0.02 a 300.00 s (step 0.01 s)
	Directionality: yes/no	Reset time: 0.2 a 1200.0 s (step 0,1s)	
	Activation level, current with curve: 110%	Block function if phase b voltage is lower tan 30 volts	
	Reset level, current with curve: 100%	Activation level: 100%	
	Activation level, current with definite-time: 100%	Underfrequency reset level: activation level + 50mHz	
	Reset level, current with definite-time: 95%	Overfrequency reset level: activation level – 50 mHz	
	Voltage activation level: 100%	Temporized reset	
	Voltage reset level: 95%	Accuracy 30ms maximum respect of adjusted time	
	Instant reset	46	Breaker state: start, open, closed, error, opening time, opening error, closure time, closure error
	Timing accuracy: 5% or 30 ms (whichever is higher)		52a input and/or 52b input
	Operating angle: 0 to 359° (step 1°)		Opening and closure commands
Half cone angle: 0 to 170° (step 1°)	Maximum number of openings alarm: 1 a 10000		
Function permission : yes/no	Total amps alarm: 0 to 100000 (MA ²)		
46	Operating range: 0.10 to 1 xIn (step 0.01)	Excess repeated openings: 1 a 10000	
	IEC 60255-151 and ANSI curves	Repeated openings excess time: 1 to 300 min	
	Operating time: Inverse curve, very inverse curve, extremely inverse curve. Definite-time: 0.02 to 300.00 s (step 0.01 s)		
	Dial: 0.05 to 2.20 (step 0.01)		
	Activation level with curve: 120%		
	Reset level with curve: 100%		
	Activation level with definite-time: 100%		
	Reset level with definite-time: 95%		
	Instant reset		
	Timing accuracy: 5% or 30 ms (whichever is higher)		
	Operating angle:		

50BF	Function permission : yes/no
	Opening failure time: 0.02 to 1.00 s (step 0.01 s)
	Open breaker activation threshold: 8% In
	Open breaker reset time: 10% In
79	Function permission : yes/no
	Wait permission: yes/no
	Number of reclosings: 1 a 5
	Reclosure times 1, 2, 3, 4, 5 : 0.02 to 300.00 s (step 0.01 s)
	Hold time: 0.02 to 300.00 s (step 0.01 s)
	Locking possibilities: pulse inputs, level inputs, commands.
	Reset time: 0.02 to 300.00 s (step 0.01 s)
	Definite opening time: 0.02 to 300.00 s (step 0.01 s)
25	Closure permission LLLB, LLDB, DLLB, DLDB: yes/no
	Live line/bar voltage level: 30,0 a 110,0V (step 0,1)
	Dead line/bar voltage level: 4,0 a 110,0V (step 0,1)
	Voltage supervision temporisation: 0.02 a 300 s (step 0.01)
	Line-bar voltage difference: 4,0 a 110,0V (step 0,1)
	Line-bar phase difference: 0 a 359° (step 1)
	Line-bar frequency difference : 0.02 a 0,50 Hz (step 0.01)
	Temporización sincronismo: 0.02 a 300 s (step 0.01)
	Phase B line voltage and busbar voltage: - Modules and phases using DFT - Frequency using hardware circuit with the passing through zero detection.
	Permission signal minimum time 150 ms
	74TCS
Operating time: 0.02 to 300 s (step 0.01 s)	
Command voltage presence: -40%	
Trip continuity, in circuit a and b.	
CLP	Function permission : yes/no
	50P_1 multiplier range: 1 a 5
	50P_2 multiplier range: 1 a 5
	67P_1 multiplier range: 1 a 5
	67P_2 multiplier range: 1 a 5
	50N_1 multiplier range: 1 a 5
	50N_2 multiplier range: 1 a 5
	67N_1 multiplier range: 1 a 5
	67N_2 multiplier range: 1 a 5
	Time to pass to CLP: 1 a 18000 s (step 1 s)
	CLP duration time: 1 a 18000 s (step 1 s)
CLP activation threshold: 8% In	
CLP reset threshold: 10% In	
Settings tables	1 general settings table
	3 protection criteria tables
	Selectable by input or general setting.
RTC	Condenser charge time: 10 minutes
	Functioning without auxiliary voltage: 72 hours
Oscillography	16 samples/cycle
	Oscillo starting configuration
	2 logs: 10 cycles pre-fault and 128 post-fault
	COMTRADE IEEE C37.111-1991
	8 analogue channels and 120 digital channels

Fault report	20 fault reports with 80 events in each
8 configurable inputs	The voltage of the inputs is the same as the auxiliary power supply
7 configurable outputs	250 V AC – 8 A 30 V DC – 5 A Output 1 and output 2: Commuted (NC + NO) Others: NO
Frequency	50/60Hz
Current measurement	Phase currents (IA,IB,IC), neutral (IN), positive sequence (I1) and negative sequence (I2)
	Real RMS
	Sampling: 16 samples/cycle 2% precision in a band covering ±20% of nominal current and 4% in the rest of the range
Voltage measurement	Phase voltage (VA,VB,VC), phase-phase voltage (VAB,VBC,VCA), neutral voltage (VN), bus voltage (VBB)
	The neutral voltage is calculated internally from the phase voltages.
	Real RMS Sampling: 16 samples/cycle 2% precision in a band covering ±20% of nominal current and 4% in the rest of the range
Angle accuracy	±1°
Power measurement	Total and per phase 3 phase active power
	Total and per phase 3 phase reactive power
	Total and per phase 3 phase apparent power
	Total and per phase power factor
	2% accuracy in rated values with power factor between 1 and 0.7 (phase shift from 0 to ±45°).
Energy measurement	Positive and negative active energy
	Positive and negative reactive energy
Frequency measurement	Starting from phase B line voltage, passing through zero detection to line frequency Starting from phase B busbar voltage, passing through zero detection to busbar frequency.
	Minimum voltage: 30V
	Accuracy: ±0.01 Hz
Communications	Local port: Modbus RTU
	Remote port: Modbus RTU
	Remote port: IEC 60870-5-103 (No compact SILB)
	IEC 61850 (Compact SILB)
	DNP 3.0 (Compact SILB)
Auxiliary power supply	90 V DC – 300V DC / 110 V AC – 230 V AC ±20%
	24V DC - 48 V DC ±20%
Environmental conditions	Operating temperature: -10 to 70°C
	Storage temperature: -20 to 80 °C
	Relative humidity: 95%
Mechanical characteristics	Metal case
	Panel mounting
	1/2 Rack – 4 U
	IP-54

Technical specifications

Connections diagram SIL-B

3 PHASE CURRENT TRANSFORMERS AND 1 NEUTRAL

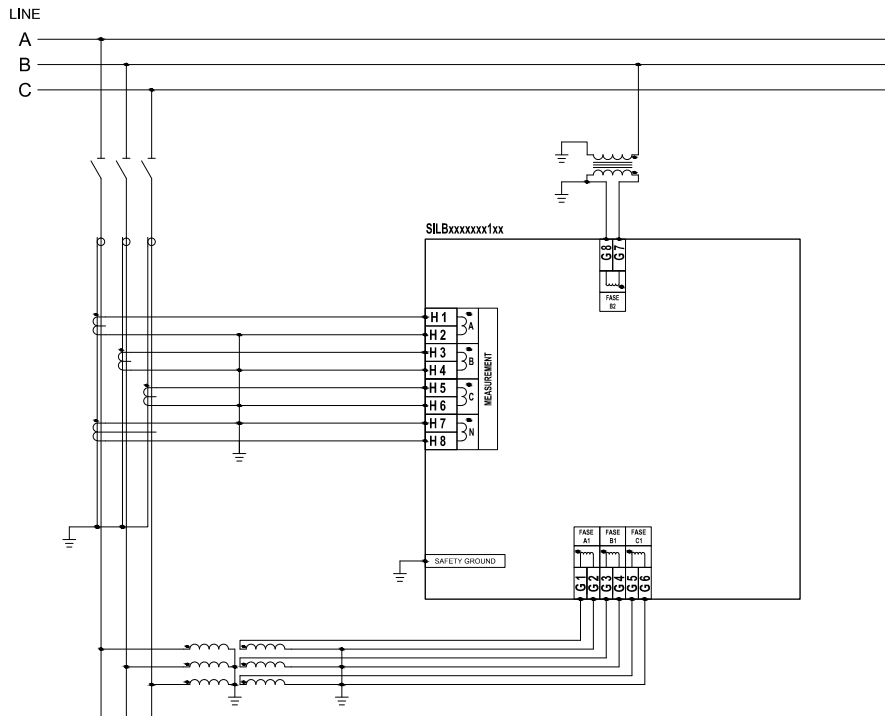
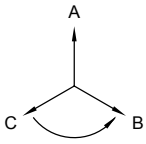

3 PHASE CURRENT TRANSFORMERS

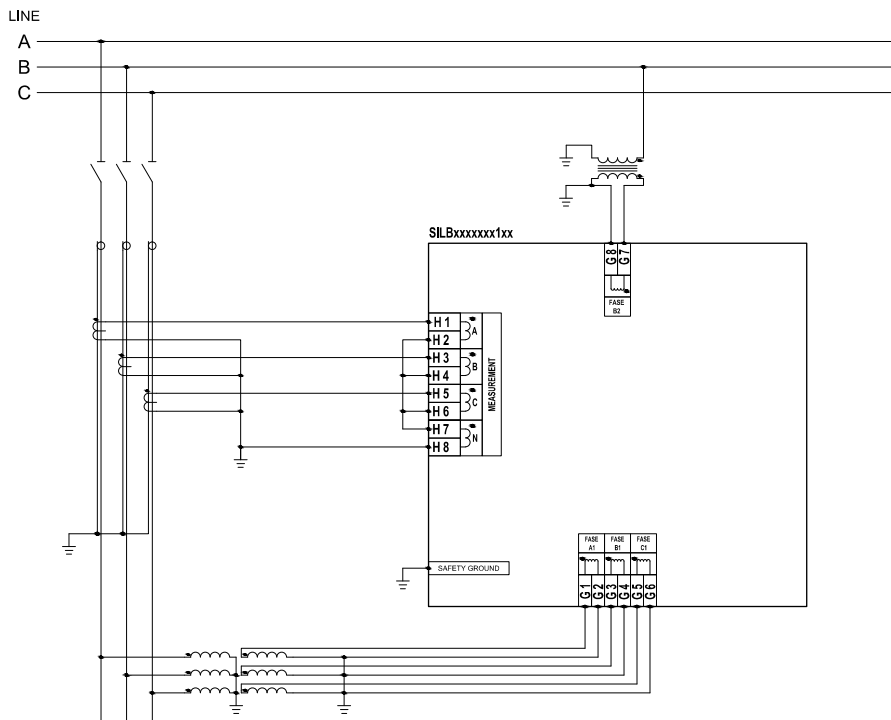
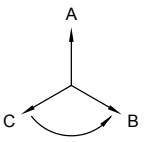

Dimensions and cutout pattern SIL-B

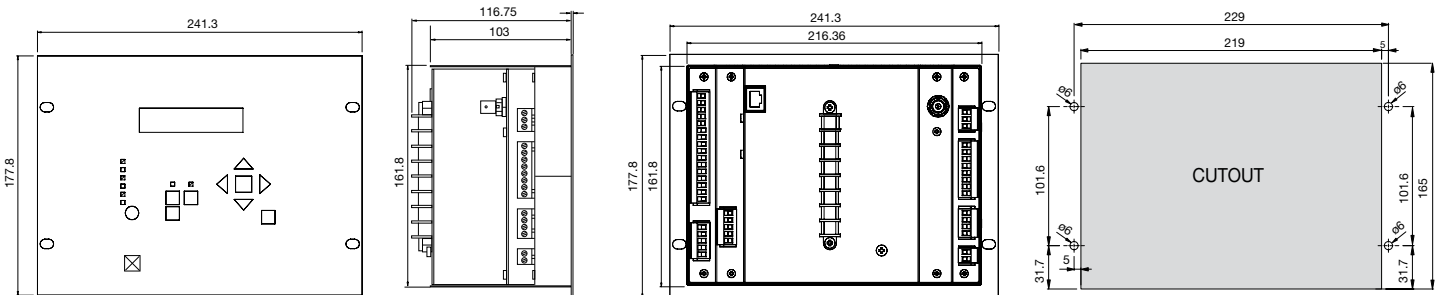

Model list SIL-B

TYPE	PHASE MEASUREMENT	NEUTRAL MEASUREMENT	NET FREQUENCY	POWER SUPPLY	ADDITIONAL FUNCTIONS	COMMUNICATIONS	INPUTS - OUTPUTS	MECHANICS	LANGUAGE	ADAPTATION
SILB										50P(2) + 67P(2) + 50N(2) + 67N(2) + 46 + 59P(2) + 59N(2) + 27P(2) + 32(4) + 52 + 50BF + 79 + 74TCS + Cold Load Pickup + 49
	1 5									1 A 5 A
		1 5								1 A 5 A
			5 6							50 Hz 60 Hz
				A B						24 - 48Vdc 90 - 300Vdc / 110 - 230Vca
					0 1 2					- + 81U/O(4) + 25 + 37(2) + 81U/O(4) + 25 + 37(2) + IIRIG-B
						0 1 2 3 4 5				RS485: ModBus + IEC 60870-5-103 FOP: ModBus + IEC 60870-5-103 FOC-ST: ModBus + IEC 60870-5-103 <i>(Only in compact version)</i> IEC61850 + ModBus (RS485) DNP3.0 (TCP/IP) + ModBus (RS485) IEC 60870-5-104 + ModBus (RS485)
							0			7 outputs + 8 inputs
								0 1		With external MMS module: 4U x 1/2 rack Compact: 4U x 1/2 rack
									A B D	English, Spanish, French and German English, Spanish, French and Turkish English, Spanish, French and Russian
									A	-

Note: Common technical specifications and accessories, page 42.

Accessories

Battery power supply KitCom

The KitCom is an adapter that allows you to feed SIA relays from the front communications port, allowing also to communicate with the computer locally.

For SIA-C/SIA-D (DB9) and SIA-F/SIA-B (USB) the power comes from two AA batteries of 1.5 Volts placed at the bottom of the device. The equipment has a small Dc / Dc power supply raising the voltage required valve to operate the equipment. This operation includes the energy necessary to trip. This is important in the commissioning processes of the transformation centres, allowing full verification of the centre, without any auxiliary power supply.

The equipment has a microswitch that feeds the power supply with a LED (ON) when the voltage is 12 adequate.

The Kitcom for SIA-A and SIA-E relays uses the model of 9 volts (GLR-61) battery.

In addition to all the necessary to give the power supply, this device has two LED associated with the Rx and Tx lines of communication, and they are used to verify that there is data traffic between the PC and the SIA relay.



Striker PRT

This is a single effect solenoid. The striker is spring operated.

The striker is activated by low-power polarised electrical signal supplied by the relay in case of a fault.

The striker is reset to its starting position manually.

Travel: 8 mm

Spring strength:

- Start of travel: 37 N
- End of travel: 18 N

Response time: 4 ms

Protection rating: IP-40

Trip coil module TCM

This item is connected to the potential-free trip contact of the relay and supplies the energy needed to trip the coil (30J).

It is loaded using the auxiliary voltage supply of the transformation centre and retains power for up to 3 days without external power supply.

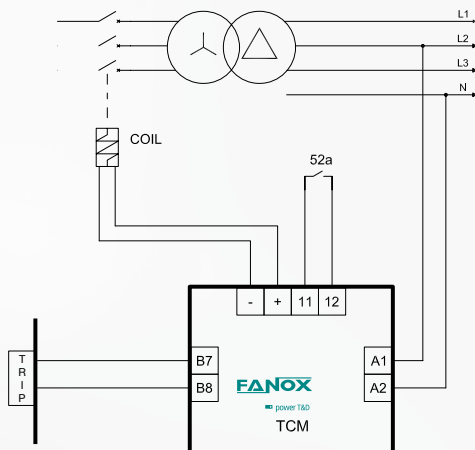

	POWER SUPPLY	OUTPUT VOLTAGE FOR TRIP COIL	ADAPTATION
TCM			
	1		230 Vac
	2		110 Vac
		A	48 Vdc
		B	110 Vdc
		C	220 Vdc
		-	Available for SIA-A and SIA-E
		A	Available for SIA-C* and SIA-D

*SIA-C with potential-free contact

CUSTOMIZED PRODUCTS AND BRANDLABELING

Every day an increasing number of companies are considering the option of outsourcing their design and product development.

Fanox is the perfect technology partner to carry out these activities. Our R & D department is prepared to operate as an integral part of our clients business adapting to their needs y developing custom designs.

Fanox is a leader in the customization of products for reputable manufacturers, and we offer added value at a very competitive price. Fanox provides additional performance characteristics to the equipment thanks to continuous improvement of electronics spear heading a rapidly moving technology sector.

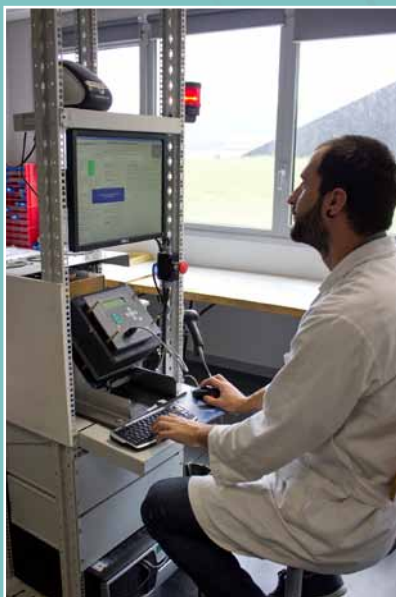



power T&D

FANOX is involved in all levels of electrical distribution, both primary and secondary, and has a great deal of experience in designing and producing customized equipment for manufacturers of primary substations with relation to protection control, measurement and communication, and is an important reference within this field.

5
Five year
guarantee

Parque Tecnológico de Bizkaia
Astondo bidea, Edif. 604
48160 DERIO (Spain)

tel.: (+34) 94 471 14 09
fax.: (+34) 94 471 05 92
mail: fanox@fanox.com

www.fanox.com



Fanox reserves the right to modify technical specification of products contained within this catalogue without previous notice.